

PerformAA™ Auto Air Assist Spray Guns

3A8553D

EN

Air assist spray guns for fine finish application of various solventborne and waterborne paints and coatings. For professional use only.

4000 psi (28 MPa, 280 bar) maximum working fluid pressure.

100 psi (0.7 MPa, 7 bar) maximum working air pressure.

See page 3 for model information.



Important Safety Instructions

Read all warnings and instructions in this manual before using the equipment. Save these instructions.



Important Medical Information

Read the medical alert card provided with the gun. It contains injection injury treatment information for a doctor. Keep it with you when operating the equipment.

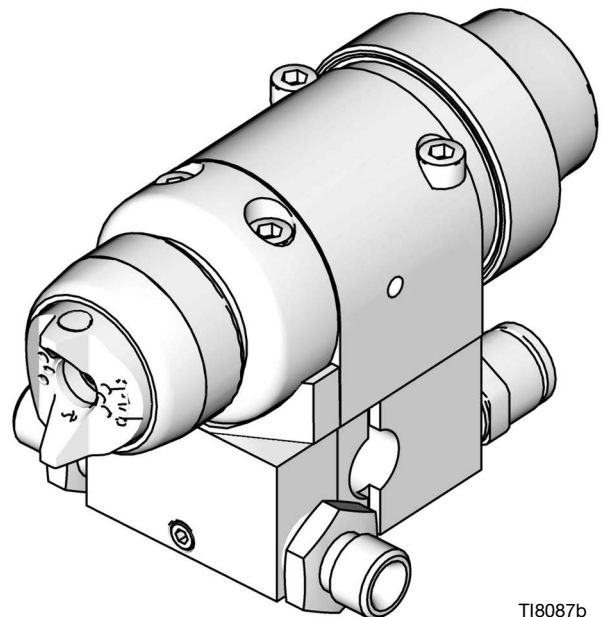

T18087b

Model 26B570 Spray Gun shown mounted on Model 288217 Manifold



II 2 G Ex h IIB T6 Gb

Contents

Models	3	Service	22
Warnings	4	Disassembly	22
Installation	6	Diffuser Seat Replacement	24
Ventilate the Spray Booth	6	Reassembly	24
Configure Gun and Manifold	6	Spray Tip Gasket Replacement	25
Install Air Fittings	7	Parts	26
Grounding	7	Compatible Air Assist Manifolds	28
Mount Gun	8	Spray Tip Selection Charts	32
Connect Air Line	9	AXP Spray Tips	32
Connect Fluid Hose	10	AXF Spray Tips	33
Setup	11	AXP and AXF Spray Tip Gasket Assembly and Kits	33
Flush Before Using	11	LTX and FFLP RAC Spray Tips	34
Select a Spray Tip and Air Cap	11	Wide (WR) RAC Spray Tips	35
Install a Spray Tip and Air Cap	11	RAC Spray Tip Assembly and Kits	35
Air Cap Alignment Tool Procedure	12	Air Cap Selection Chart	36
Air Cap Alignment Pin	12	Kits and Accessories	37
Reverse-A-Clean® (RAC) Spray Tip Setup	13	Carbide Needle Assembly, 288191	39
Operation	14	SST Needle Assembly, 288190	39
Pressure Relief Procedure	14	Fluid Seal Repair Kit, 288136	40
Adjust the Spray Pattern	14	Plastic Seat Kit, 249424	40
Spray Finishing Application	15	Air Seal Repair Kit, 288171	40
Maintenance	16	Carbide Seat Kit, 249456	40
Daily Gun Care	16	Dimensions	42
General System Maintenance	16	Mounting Hole Layout	43
Flushing and Cleaning	16	Manifolds	44
Troubleshooting	19	Technical Specifications	49
General Troubleshooting	19	California Proposition 65	50
Spray Pattern Troubleshooting	21	Air Flow	51
		Graco Standard Warranty	52

Models

PerformAA Auto Air Assist Models









Gun includes carbide seat and ball, indexing air cap, and choice of AXP spray tip (unless otherwise noted).

A manifold is required to install and operate the spray gun. Manifolds are sold separately. See **Gun Manifolds**, page 37.

Model	Air Cap	Air Cap Part No.
26B570	General Finishing (GF)	2GF042
26B571	Lacquer (WL)	2WL042
26B572*	General Finishing (GF)	2GF042
26B573‡	Reverse-A-Clean® (RAC)	249478
26B574	Low Viscosity (LV)	2LV042
26B575	Waterborne (WB)	2WB042
26B576	Quick Drying (QD)	2QD042
26B577	High Viscosity (HV)	2HV042
*Gun with a plastic seat, SST ball; designed to handle low viscosity, non-abrasive or acid-catalyzed material.		
‡ Includes choice of LTX or FFLP Reverse-a-Clean (RAC) Spray Tip.		

Warnings

The following are general warnings related to the setup, use, grounding, maintenance, and repair of this equipment. Additional, more specific warnings may be found throughout the body of this manual where applicable. Symbols that appear in the body of the manual refer to these general warnings. When these symbols appear throughout the manual, refer back to these pages for a description of the specific hazard.

 <h1 style="margin: 0;">WARNING</h1>	
   	<p>FIRE AND EXPLOSION HAZARD</p> <p>Flammable fumes, such as solvent and paint fumes, in work area can ignite or explode. Paint or solvent flowing through the equipment can cause static sparking. To help prevent fire and explosion:</p> <ul style="list-style-type: none"> • Use equipment only in well-ventilated area. • Eliminate all ignition sources; such as pilot lights, cigarettes, portable electric lamps, and plastic drop cloths (potential static sparking). • Ground all equipment in the work area. See Grounding, instructions. • Never spray or flush solvent at high pressure. • Keep work area free of debris, including solvent, rags and gasoline. • Do not plug or unplug power cords, or turn power or light switches on or off when flammable fumes are present. • Use only grounded hoses. • Hold gun firmly to side of grounded pail when triggering into pail. Do not use pail liners unless they are anti-static or conductive. • Stop operation immediately if static sparking occurs or you feel a shock. Do not use equipment until you identify and correct the problem. • Keep a working fire extinguisher in the work area.
  	<p>SKIN INJECTION HAZARD</p> <p>High-pressure fluid from dispensing device, hose leaks, or ruptured components will pierce skin. This may look like just a cut, but it is a serious injury that can result in amputation. Get immediate surgical treatment.</p> <ul style="list-style-type: none"> • Do not point dispensing device at anyone or at any part of the body. • Do not put your hand over the fluid outlet. • Do not stop or deflect leaks with your hand, body, glove, or rag. • Follow the Pressure Relief Procedure, when you stop dispensing and before cleaning, checking, or servicing equipment. • Tighten all fluid connections before operating the equipment. • Check hoses and couplings daily. Replace worn or damaged parts immediately.
	<p>TOXIC FLUID OR FUMES HAZARD</p> <p>Toxic fluids or fumes can cause serious injury or death if splashed in the eyes or on skin, inhaled, or swallowed.</p> <ul style="list-style-type: none"> • Read Safety Data Sheets (SDSs) to know the specific hazards of the fluids you are using. • Store hazardous fluid in approved containers, and dispose of it according to applicable guidelines.



WARNING



EQUIPMENT MISUSE HAZARD

Misuse can cause death or serious injury.



- Do not operate the unit when fatigued or under the influence of drugs or alcohol.
- Do not exceed the maximum working pressure or temperature rating of the lowest rated system component. See **Technical Specifications** in all equipment manuals.
- Use fluids and solvents that are compatible with equipment wetted parts. See **Technical Specifications** in all equipment manuals. Read fluid and solvent manufacturer's warnings. For complete information about your material, request Safety Data Sheets (SDSs) from distributor or retailer.
- Turn off all equipment and follow the **Pressure Relief Procedure**, when equipment is not in use.
- Check equipment daily. Repair or replace worn or damaged parts immediately with genuine manufacturer's replacement parts only.
- Do not alter or modify equipment. Alterations or modifications may void agency approvals and create safety hazards.
- Make sure all equipment is rated and approved for the environment in which you are using it.
- Use equipment only for its intended purpose. Call your distributor for information.
- Route hoses and cables away from traffic areas, sharp edges, moving parts, and hot surfaces.
- Do not kink or over bend hoses or use hoses to pull equipment.
- Keep children and animals away from work area.
- Comply with all applicable safety regulations.



PERSONAL PROTECTIVE EQUIPMENT

Wear appropriate protective equipment when in the work area to help prevent serious injury, including eye injury, hearing loss, inhalation of toxic fumes, and burns. Protective equipment includes but is not limited to:

- Protective eyewear, and hearing protection.
- Respirators, protective clothing, and gloves as recommended by the fluid and solvent manufacturer.

Installation

Ventilate the Spray Booth



Do not operate the gun unless ventilating air flow is above the minimum required value. Provide fresh air ventilation to avoid the buildup of flammable or toxic vapors when spraying, flushing, or cleaning the gun. Interlock the gun fluid supply to prevent operation unless ventilating air flow is above the minimum required value.

The spray booth must have a ventilation system.

Electrically interlock the gun fluid supply with the ventilators to prevent gun operation any time that the ventilation air flow falls below minimum values. Check and follow all local codes and regulations regarding air exhaust velocity requirements. Verify the operation of the interlock at least once a year.

Configure Gun and Manifold

The gun is supplied with an internal fluid plug and seals (5, 6, 7). To use the gun in a circulating system, remove the internal plug. In a non-circulating system, leave the plug in place to minimize flush time.

Circulating System

1. Apply anti-seize lubricant 222955 to the threads and mating faces of the manifold (101) and the elbows (107), supplied unassembled.
2. Install the elbows (107) in both fluid ports of the manifold (101).
3. Connect the fluid supply hose to one elbow and the fluid return hose to the other. The manifold fluid ports are reversible.
4. Install the gun on the manifold, using the four screws (17). Start the threads of all four screws,

and tighten the front two screws first, and then tighten the back two screws to 65 in-lb (7.3 N•m).

Non-circulating System

1. See FIG. 1. Apply anti-seize lubricant 222955 to the threads and mating faces of the manifold (101), plug (109), and elbow (107), supplied unassembled.
2. Install an elbow (107) in one fluid port of the manifold (101), and a plug (109) in the other port.
3. Install the internal plug (5) in the gun fluid port on the same side as the manifold plug.
4. Connect the fluid supply hose to the manifold elbow (107).
5. Install the gun on the manifold, using the four screws (17). Start the threads of all four screws, and tighten the front two screws first, and then tighten the back two screws to 65 in-lb (7.3 N•m).

- ⚠ 1 Remove when used in circulating systems.
- ⚠ 2 Replace with a reducing nipple (107) when used in circulating systems.
- ⚠ 3 Install optional filter in fluid inlet port. See **Kits and Accessories**, page 37.

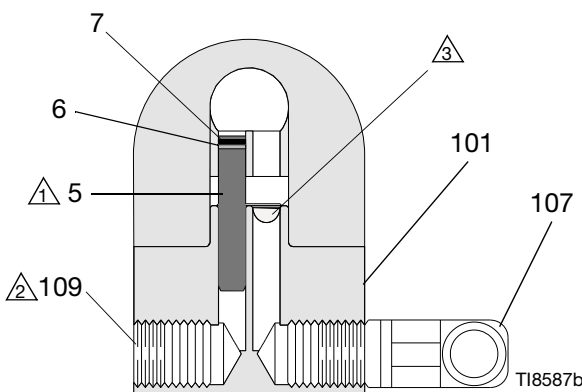

FIG. 1: Non-Circulating Setup Shown (cutaway view)

Install Air Fittings

1. Install the supplied 1/4 in. (6 mm) tube fitting into the cylinder (CYL) air port.
2. Install 3/8 in. (8 mm) tube fittings into the atomization (ATOM) air port and the fan (FAN) air port.

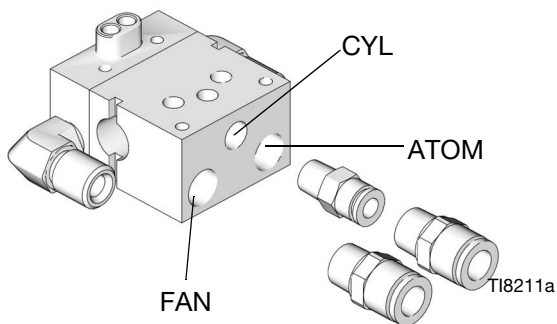

FIG. 2: Air fittings installation

Grounding

<p>The equipment must be grounded to reduce the risk of static sparking. Static sparking can cause fumes to ignite or explode. Grounding provides an escape wire for the electric current.</p>				

The following grounding instructions are minimum requirements for a system. Your system may include other equipment or objects that must be grounded. Check your local electrical code for detailed grounding instructions for your area and type of equipment. Your system must be connected to a true earth ground.

Spray Gun: Ground the spray gun by mounting it to a grounded mount, such as a reciprocator, robot, or stationary support, and connect it to a properly grounded fluid hose and pump.

Pump: Ground the pump by connecting a ground wire and clamp between the pump and a true earth ground as instructed in your separate pump instruction manual.

Air Compressors and Hydraulic Power Supplies: Ground air compressors and hydraulic power supplies according to the manufacturer recommendations.

Air, Fluid, and Hydraulic Hoses Connected To Pump: Use only electrically conductive hoses with a maximum of 100 ft (30.5 m) combined hose length to ensure grounding continuity. Check the electrical resistance of your air and fluid hoses at least once a week. If the total resistance to ground exceeds 25 megohms, replace the hose immediately. Use a meter that is capable of measuring resistance at this level.

Fluid Supply Container: Ground the fluid supply container according to local code.

Object Being Sprayed: Ground the object that is being sprayed according to local code.

Solvent Pails: Ground all solvent pails that are used when flushing according to local code. Use only metal pails, which are conductive. Do not place the pail on a non-conductive surface, such as paper or cardboard, which interrupts the grounding continuity.

Mount Gun

Reciprocating Arm Rod Mount

To mount the gun on a reciprocating arm rod [0.5 in. (13 mm) diameter maximum]:

1. Insert the mounting bar (A) through the hole in the manifold as shown in FIG. 3.

NOTE: Use the 1/8 in. alignment pin (P) to assist in orienting the gun.

2. Secure the gun to the bar by tightening the mounting screw (B).

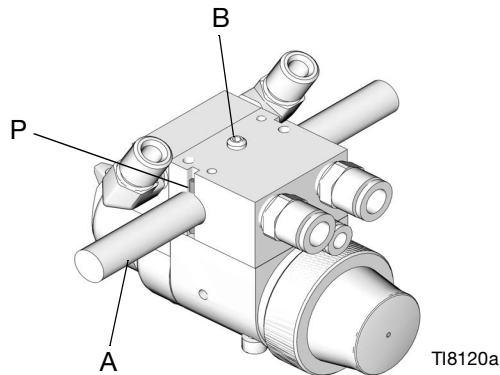

FIG. 3: Reciprocating Arm Mount

Stationary Support

To mount the gun on a stationary support (refer to FIG. 4. and to **Mounting Hole Layout**, page 43):

1. Align the manifold with the alignment pins. Locate alignment pins and holes per the **Mounting Hole Layout** illustration, page 43.
2. Secure the gun to the support with two M5 x 0.8 capscrews (S). The screws must be long enough to

engage the threaded holes in the gun manifold to a depth of 1/4 in. (6 mm).

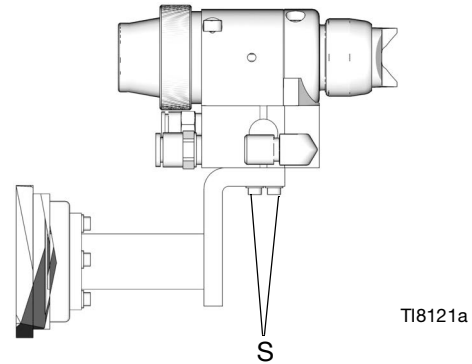

FIG. 4: Stationary Support Mount

Retrofit Adapter Plate

The retrofit adapter plate enables the manifold to be attached to a variety of bolt patterns.

To mount the gun using the retrofit adapter plate (kit 288197):

1. Mount adapter plate to manifold using the three screws provided with the kit (FIG. 5).
2. Bolt plate to mounting surface using four M5 x 0.8 capscrews. Refer to the **Mounting Hole Layout**, page 43.

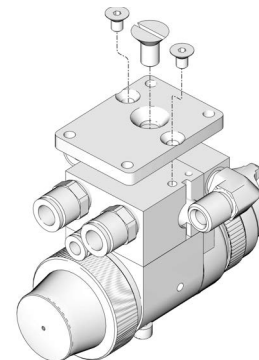

FIG. 5: Retrofit Adapter Plate

T18180a

Connect Air Line

1. Install an air/water separator and an air line filter to ensure a clean, dry air supply to the gun. Dirt and moisture in the line can ruin the appearance of your finished piece.
2. Install an air pressure regulator on each gun air supply line.
3. For manifolds with separate fan and atomization ports, the gun cylinder, fan, and atomization air must be supplied and regulated separately. For adjustable manifolds with a manual valve, only one supply line is required for both atomization and fan air.

NOTE: A minimum of 50 psi (0.34 MPa, 3.4 bar) air pressure must be supplied to the cylinder for proper operation. Set the atomization air as needed for complete atomization of the entire pattern. The tip size is the primary controller of the pattern size. Use the fan air only as needed to slightly adjust the pattern size.

4. Install a bleed-type master air shutoff valve on the main air line. Install an additional bleed-type valve on each pump air supply line, downstream of the pump air regulator, to relieve air trapped between this valve and the pump after the air regulator is shut off.

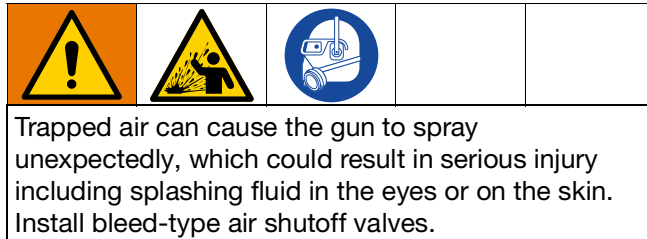

5. Install a bleed-type air shutoff valve on each gun air supply line, downstream of the gun air regulator, to shut off air to the gun.
6. For manifolds with separate fan and atomization ports, connect a separate air supply line to the gun atomizing air inlet (D) and cylinder air inlet (C). Connect an air supply line to the fan air inlet (E) if desired. See FIG. 6. For manifolds with a manual fan valve, only one supply line is required for both atomization and fan air.

NOTE: The gun atomizing and fan air inlets are 3/8 in. (9.5 mm) O.D. tubing compatible. The cylinder air inlet accepts 1/4 in. (6.3 mm) O.D. tubing.

Connect Fluid Hose

NOTE: A fluid drain valve(s) is required in your system to assist in relieving fluid pressure in the displacement pump, hose and gun; triggering the gun to relieve pressure may not be sufficient.

NOTE: A fluid pressure regulator must be installed in the system if the pump's maximum working pressure exceeds the gun's maximum fluid working pressure (see the front cover).

Before connecting the fluid hose, blow it out with air and flush it with solvent. Use solvent that is compatible with the fluid to be sprayed.

1. Install a fluid filter and drain valve(s) close to the pump's fluid outlet.
2. Install a fluid pressure regulator to control fluid pressure to the gun.

NOTE: Some applications require fine-tuned control of fluid pressure. You can control fluid pressure more accurately with a fluid pressure regulator than by regulating the air pressure to the pump.

3. Install a fluid shutoff valve to shut off the fluid supply to the gun.
4. Install an in-line fluid filter on the gun fluid inlet (F) to avoid clogging the spray tip with particles from the fluid. See FIG. 6.
5. **In a circulating system,** connect a grounded fluid supply hose to the gun fluid fitting. Connect a grounded return hose to the other port.

In a non-circulating system, remove the gun fluid outlet fitting (G) and plug the outlet port with the pipe plug (109) supplied.

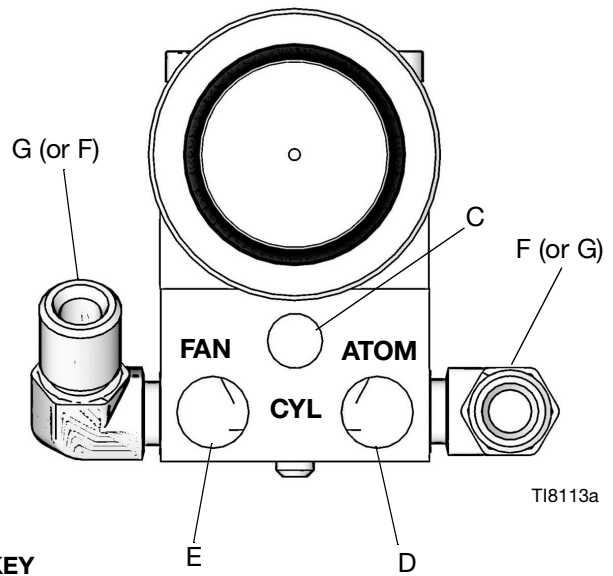

KEY

- C Cylinder Air Inlet: accepts 1/4 in. (6.3 mm) O.D. tubing
- D Atomization Air Inlet: 1/4-18.6 npsm
- E Fan Air Inlet: 1/4-18.6 npsm
- F Fluid Inlet: 1/4-18 nptf or #5 JIC (1/2-20 unf)
- G Fluid Outlet (circulating gun only): 1/4-18 nptf or #5 JIC (1/2-20 unf)

FIG. 6: Side Mounted Air Assist Manifold Ports

Setup

Flush Before Using

The equipment was tested with lightweight oil, which is left in the fluid passages to protect parts. To avoid contaminating your fluid with oil, flush the equipment with a compatible solvent before using the equipment. See **Flushing and Cleaning**, page 16.

Follow the **Pressure Relief Procedure**, page 14.

Select a Spray Tip and Air Cap

The fluid flow and pattern width depend on the size of the spray tip, the fluid viscosity, and the fluid pressure. See **Spray Tip Selection Charts**, page 32. Contact your Graco distributor for assistance in selecting an appropriate spray tip for your application.

Install a Spray Tip and Air Cap

				
<p>To avoid serious injury from skin injection, do not put your hand in front of the spray tip when installing or removing the spray tip and tip guard.</p>				

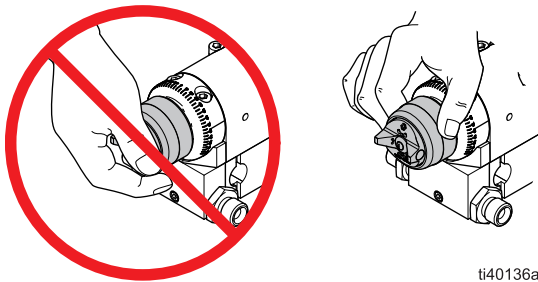

1. Follow the **Pressure Relief Procedure**, 14.

2. Install a spray tip in the gun. Align tip locating tab with slot on the air cap.

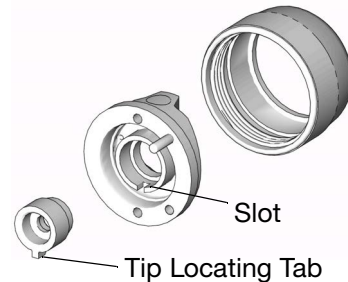

FIG. 7: Spray tip and air cap setup

3. Rotate the air cap to a horizontal, vertical, or angled spray pattern.

NOTE: Manually adjust angled spray patterns to approximate position before using the optional Air Cap Alignment Tool.

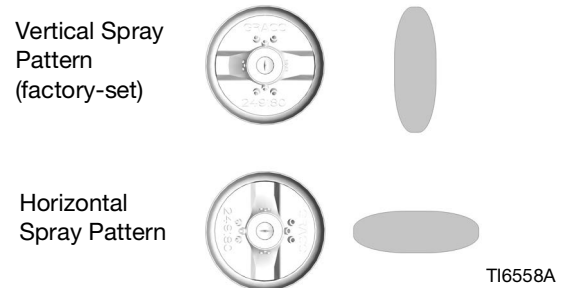

FIG. 8: Spray pattern positions

4. Tighten the air cap retaining ring (8) firmly by hand to ensure a proper seal between the tip gasket and the diffuser (10).

Optional: Use an Air Cap Alignment Tool to quickly set the spray pattern to an exact angle. See **Air Cap Alignment Tool Procedure**, page 12.

Air Cap Alignment Tool Procedure

Use an alignment tool (26B736) to quickly set exact spray pattern angles.

NOTE: The alignment tool is sold separately.

1. Place the alignment tool onto the tightened retaining ring (8).

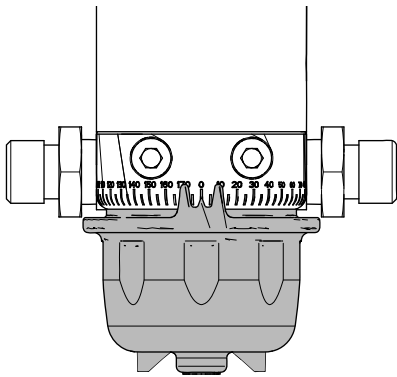

ti40301a

FIG. 9: Alignment tool on an air cap in the vertical position (0°)

2. Rotate the alignment tool to the desired angled spray pattern position.

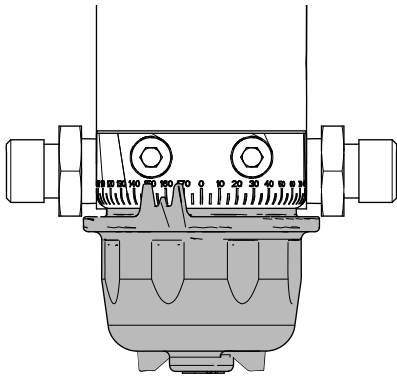

ti40302a

FIG. 10: 160° angled spray pattern

3. Remove the alignment tool.

Air Cap Alignment Pin

Air caps are factory-set with an air cap alignment pin to position the air cap. The standard location of the air cap alignment pin is the vertical spray pattern.

To change the spray pattern direction, use a needle nose pliers to unscrew the pin and relocate it to the desired position. See FIG. 11. When relocating the pin use low-strength thread locker. Torque to 1.5-2.5 in-lb (0.2-0.3 N•m). **Do not overtighten.**

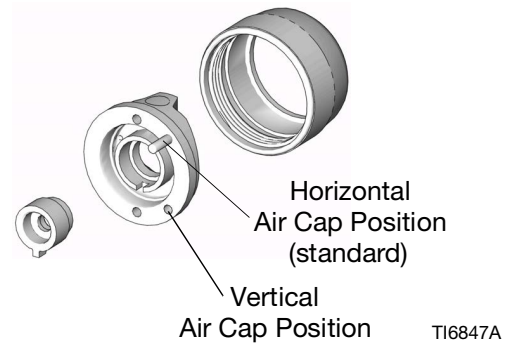

T16847A

FIG. 11: Air cap alignment pin positions

Reverse-A-Clean® (RAC) Spray Tip Setup

Convert any air assist gun models to a RAC gun model with RAC Conversion Kit 287917. See **Kits and Accessories**, page 37.

NOTE: Replace the seat and gasket part as needed. See **RAC Spray Tip Assembly and Kits**, page 35.

1. Follow the **Pressure Relief Procedure**, page 14.
2. Insert the RAC housing (11) into the tip guard (46).

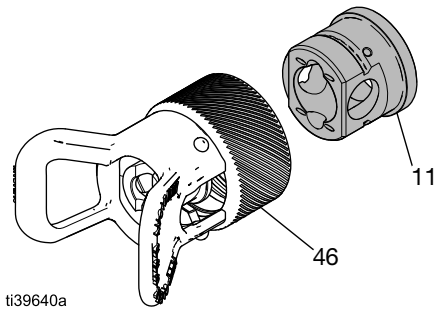

3. Insert the tip gasket seat assembly (9a).

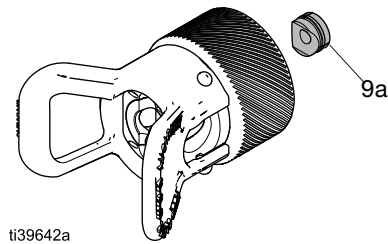

4. Screw the guard (46) onto the gun, and tighten firmly by hand.

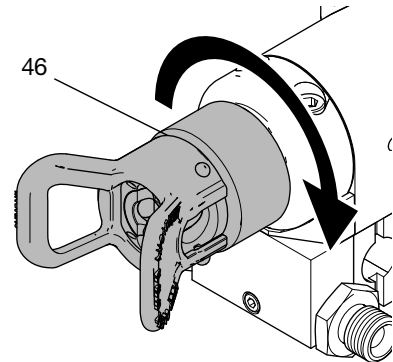

5. Insert the RAC SwitchTip (9).

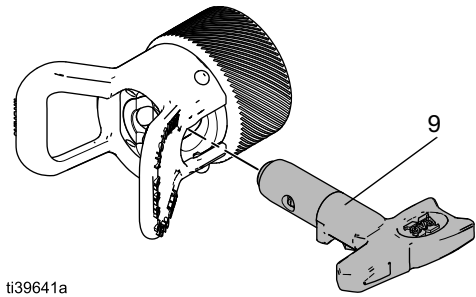

Operation

Pressure Relief Procedure



Follow the Pressure Relief Procedure whenever you see this symbol.



This equipment stays pressurized until pressure is manually relieved. To help prevent serious injury from pressurized fluid, such as skin injection and splashing fluid, follow the Pressure Relief Procedure when you stop spraying and before cleaning, checking, or servicing the equipment.

1. Turn off the air and fluid supply to the gun.
2. Close the bleed-type master air valve (required in the system).
3. Hold a metal part of the gun firmly to a grounded metal pail. Trigger the gun to relieve pressure.

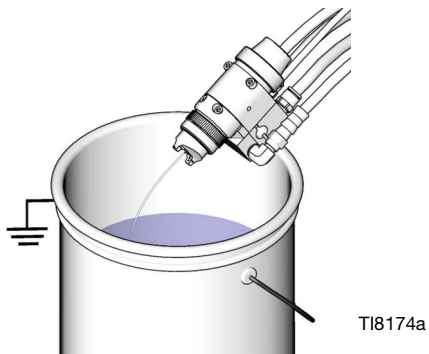

FIG. 12: Pressure Relief

4. Open the pump drain valve (required in the system) to relieve fluid pressure in the displacement pump. In addition, open the drain valve connected to the fluid pressure gauge (in a system with fluid regulation) to relieve fluid pressure in the hose and gun. Have a container ready to catch the drainage.

5. Leave the drain valve(s) open until you are ready to spray again.
6. If you suspect that the spray tip or hose is completely clogged or that pressure has not been fully relieved:
 - a. Very slowly loosen the retaining ring or the hose end coupling to relieve pressure gradually.
 - b. Loosen the coupling completely.
 - c. Clear the obstruction in the hose or tip.

Adjust the Spray Pattern



To avoid serious injury from skin injection, do not put your hand in front of the spray tip when operating the spray gun.

The air assist spray gun combines airless and air spray concepts. The spray tip shapes the fluid into a fan pattern, as does a conventional airless spray tip. Air from the air cap further atomizes the fluid and completes the atomization of the paint tails into the pattern to produce a more uniform pattern.

The fan air can be used if necessary to slightly adjust the pattern size.

NOTE: Air assist spray guns differ from air spray guns in that increasing the fan air reduces the pattern width. To increase the pattern width, use less fan air or a larger size tip.

1. Set the fluid pressure at 300 psi (2.1 MPa, 21 bar) with the fluid regulator.
2. Trigger the gun to check the atomization; do not be concerned about the pattern shape yet.
3. Slowly Increase the fluid pressure just to the point where a further increase in fluid pressure does not significantly improve fluid atomization.

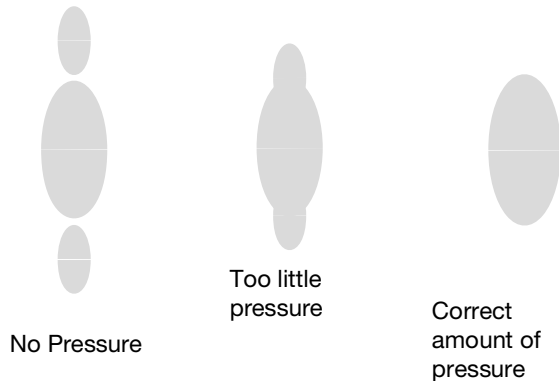

TI0792

FIG. 13: Correct Spray Pattern

- Turn on the atomizing air and set the air pressure at about 10 psi (70 kPa, 0.7 bar). Check the spray pattern, and then adjust the air pressure until the tails are completely atomized and pulled into the spray pattern. See FIG. 13. Do not exceed 100 psi (0.7 MPa, 7 bar) air pressure to the gun.

NOTE: For HVLP operation do not exceed 10 psi at the air cap. Use HVLP verification kit 249140 to measure the atomization pressure at the air cap.

- Adjust the pattern width if desired.

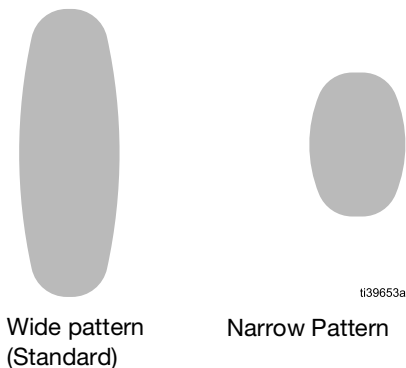

FIG. 14: Spray pattern widths

For a narrower pattern, supply air to the gun fan air inlet (or open the fan adjustment valve on adjustable manifolds). The tip size is the primary controller of the pattern size. Use the fan air only as needed to slightly adjust the pattern size.

Spray Finishing Application

The spray gun has a built-in lead and lag operation. When triggered, the gun begins emitting air before the fluid is discharged. When the trigger actuation air is stopped, the fluid stops before the air flow stops. This helps assure the spray is atomized and prevents fluid buildup on the air cap and tip.

Adjust the system control device, if it is automatic, so the gun starts spraying just before meeting the work piece and stops as soon as the work piece has passed. Keep the gun a consistent distance, 8 to 10 inches (200 to 250 mm), from the surface of the object being sprayed.

To achieve best results when applying fluid:

- Keep gun perpendicular and 8 to 10 inches (200 to 250mm) from object being sprayed.
- Use smooth, parallel strokes across surface to be sprayed with 50% overlap. See FIG. 15.

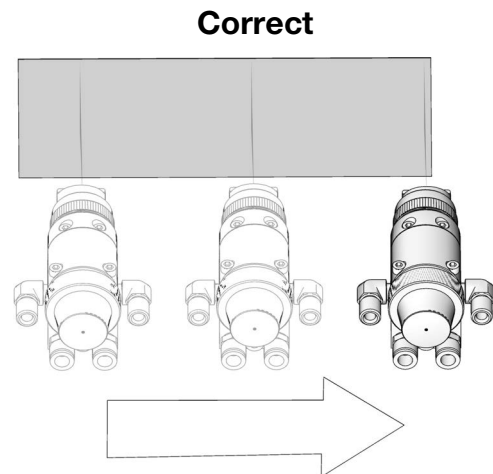
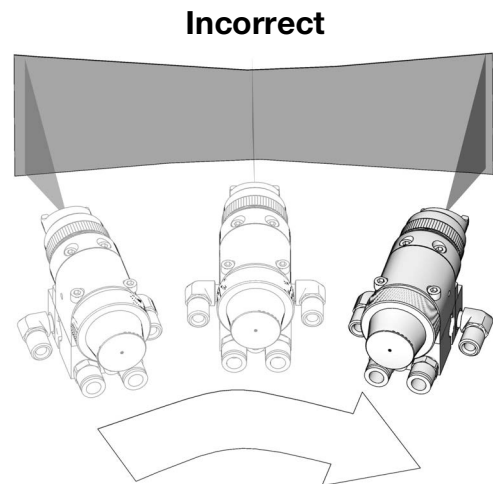

TI8098a

FIG. 15: Correct Spray Method

Maintenance

Daily Gun Care



To reduce the risk of an injury, follow the **Pressure Relief Procedure**, page 14, whenever you are instructed to relieve the pressure.

Follow the general system maintenance and flushing and cleaning procedures daily.

NOTICE	
<p>Methylene chloride with formic or propionic acid is not recommended as a flushing or cleaning solvent with this gun as it will damage aluminum and nylon components.</p>	

General System Maintenance



To reduce the risk of an injury, follow the **Pressure Relief Procedure**, page 14, whenever you are instructed to relieve the pressure.

1. Follow the **Pressure Relief Procedure**, page 14.
2. Clean the fluid and air line filters daily.
3. Check for any fluid leakage from the gun and fluid hoses. Tighten fittings or replace equipment as needed.

4. Flush the gun before changing colors and whenever you are done operating the gun.

Flushing and Cleaning

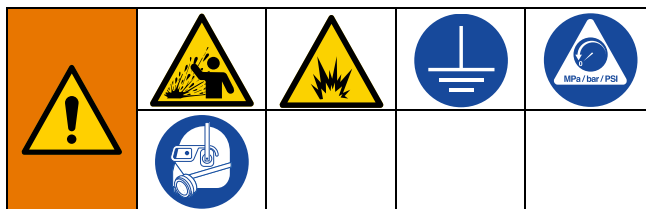

To avoid fire and explosion, always ground equipment and waste container. Maintain metal to metal contact between the gun and the flushing pail. To avoid static sparking and injury from splashing fluid, always remove the spray tip and flush at the lowest possible pressure.

This gun is not adjustable. To ensure proper shutoff, tighten the piston cap (27) onto the housing (1) until it bottoms out.

- Flush before changing colors, before fluid can dry in the equipment, at the end of the day, before storing, and before repairing equipment.
- Flush at the lowest pressure possible. Check connectors for leaks and tighten as necessary.
- Flush with a fluid that is compatible with the fluid being dispensed and the equipment wetted parts.
- Clean the front of the tip frequently during the day to reduce buildup.

NOTE: Solvent left in gun air passages could result in a poor quality paint finish. Do not use any cleaning method which may allow solvent into the gun air passages.



- Do not point gun up while cleaning.
- Do not wipe the gun with a cloth soaked in solvent; wring out the excess.
- Do not immerse the gun in solvent.
- Do not use metal tools to clean the air cap holes; this may scratch them. Scratches may distort the spray pattern.

1. Follow the **Pressure Relief Procedure**, page 14.
2. Shut off the gun fan and atomizing air.



To avoid serious injury from skin injection, do not put your hand in front of the spray tip when removing, installing, or maintaining the air cap and spray tip.

3. Remove the air cap retaining ring (8), air cap (30), and spray tip (9).
4. Disconnect the fluid supply hose and air supply hose from the gun.
5. Connect the solvent supply hose to the gun.
6. Point the gun down into a grounded metal container. Hold a metal part of the gun firmly to the grounded metal container. Increase the fluid

pressure slowly. Flush until clean solvent flows from the gun.

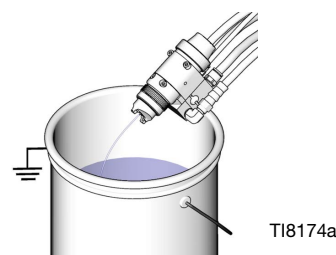

7. Turn off the solvent supply.
8. Follow the **Pressure Relief Procedure**, 14.
9. Disconnect the solvent supply hose from the gun.
10. Dip the end of a soft-bristle brush into a compatible solvent. Do not continuously soak the brush's bristles with solvent and do not use a wire brush.



11. With the gun pointed down, clean the front of the gun, using the soft-bristle brush and solvent.
12. Scrub the air cap retaining ring (8), air cap (30), and spray tip (9) with the soft-bristle brush. To clean out air cap holes, use a soft tool, such as a toothpick, to avoid damaging critical surfaces. Blow air through the spray tip to ensure the orifice is clean. Clean the air cap and spray tip daily, minimum. Some applications require more frequent cleaning.

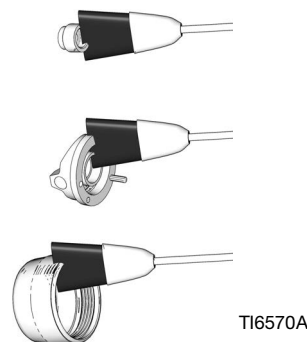

Maintenance



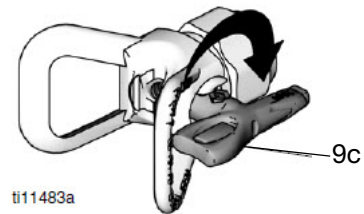

13. Install the air cap retaining ring (8), air cap (30), and spray tip (9).
14. Dampen a soft cloth with solvent and wring-out the excess. Point the gun down and wipe off the outside of the gun.

Clear a Clogged RAC Tip

1. Rotate the tip 180 so the arrow on the tip cylinder (9c) faces backward.
2. Trigger the gun into a grounded metal waste container or onto the ground to remove the clog.
3. Rotate the tip 180 back to the spray position.
4. If the RAC tip is still clogged, then follow the **Pressure Relief Procedure**, page 14, and remove the spray tip for cleaning.



Troubleshooting

				
<p>To reduce the risk of a skin injection injury, always follow the Pressure Relief Procedure, page 14, whenever instructed to relieve the pressure. To avoid serious injury from skin injection, do not put your hand in front of the spray tip when installing or removing the air cap assembly and spray tip.</p>				

NOTE: Check all possible remedies in the troubleshooting charts before disassembling the gun.



Some improper patterns are caused by the improper balance between air and fluid. Refer to **Spray Pattern Troubleshooting**, page 21.

General Troubleshooting

Problem	Cause	Solution
Fluid leakage through venting holes.	Worn packings or needle.	Replace needle assembly (14).
Air leakage through venting hole.	Worn o-ring (23) or gasket (15).	Check and replace parts as needed.
Air leakage from back of gun.	Worn o-rings (22, 23).	Replace o-rings.
Air does not trigger.	Piston stem is disconnected from main body of piston assembly (20).	Replace piston assembly.
Air does not shut off.	Piston assembly not seating properly. Broken return spring (29). Swollen o-ring (22). Worn piston stem o-rings (25, 26). Bottom gasket (16) failed.	Clean/service piston assembly. Replace worn or swollen o-rings. Replace spring. Replace o-rings. Replace o-rings. Replace gasket.
Fluid leakage from front of gun.	Fluid needle (14) dirty, worn, or damaged. Dirty or worn diffuser-seat (10).	Clean or replace fluid needle. Clean or replace diffuser-seat. To improve sealing while spraying lightweight materials and sealing life while spraying acid catalyzed materials, use optional SST ball and plastic seat.
Fluid is present at air cap holes.	Spray tip is leaking. Diffuser-seat (10) is insufficiently tightened.	Verify that retainer (8) or RAC air cap assembly (30), are tight. If so, replace spray tip (9). Tighten diffuser-seat.

Problem	Cause	Solution
Fluid needle will not trigger.	Loose or missing fluid needle stop (21) or setscrew (19). Broken fluid needle (14). Air leaking around piston (20). Swollen piston o-ring (22). Insufficient air pressure on trigger. Spray tip (9) is plugged. Fluid filter is plugged. Plug (5) is in incorrect fluid port.	Replace stop or tighten setscrew. Replace fluid needle. Replace o-ring (22) or piston assembly (20). Replace o-ring. Do not immerse piston in solvent. Increase air pressure or clean air line. Clean spray tip and air cap (30). Clean or replace filter. Move plug to fluid port consistent with manifold plumbing, unless you are using gun in a circulating system. If you are, all fluid ports in gun and on manifold should be open.
Fluid does not shut off.	Worn o-ring (25). Piston cap (27) not fully tightened. Spring (28) not in place. Swollen piston o-ring (22).	Replace o-ring. Tighten piston cap until it bottoms out. Check spring position. Replace o-ring. Do not immerse piston in solvent

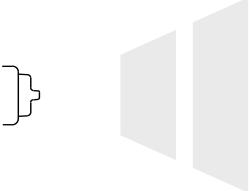
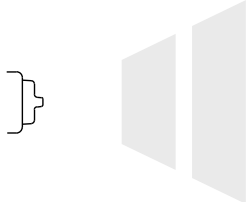
Spray Pattern Troubleshooting

Problem	Cause	Solution
<p>Fluttering spray.</p> 	<p>Insufficient fluid supply. Air in paint supply line.</p>	<p>Adjust fluid regulator or fill fluid supply tank. Check, tighten siphon hose connections, bleed air from paint line.</p>
<p>Spitting spray.</p> 	<p>Worn diffuser-seat (10) or needle (14) ball. Dirty spray tip (9) or air cap (30).</p>	<p>Inspect diffuser-seat and needle for wear. Replace if necessary. To improve sealing when spraying lightweight materials and sealing life when spraying acid catalyzed materials, use needle (SST) available with 1/8 in. ball only, and diffuser-seat (plastic). See Parts, page 26. Clean.</p>
<p>Irregular pattern.</p> 	<p>Fluid build-up or spray tip partially plugged. On defective side of pattern, air horn holes are partially or totally plugged.</p>	<p>Clean spray tip. See page 16. Clean air horn holes with solvent and soft brush. See page 16.</p>
<p>Pattern pushed to one side, same side of air cap gets dirty.</p>	<p>Air horn holes partially or totally plugged.</p>	<p>Clean air horn holes with solvent and soft brush. See page 16.</p>

Service

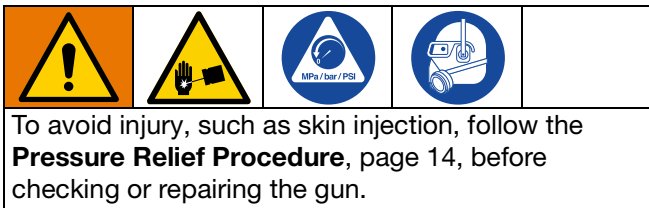

NOTE: Follow the Service Notes in FIG. 17 when reassembling the gun.

Gun repair kits are available. See page 37. Reference numbers marked with an asterisk (*) in the service procedures are included with the 288171 Air Seal Repair Kit. Reference numbers marked with a symbol (†) in the service procedures are included with the 288136 Fluid Repair Kit.

Items Needed for Service

- 1/16 in. Hex Wrench - provided
- 3 mm Hex Wrench
- Adjustable Wrench
- 4 mm Hex Wrench
- 5/16 in. Nut Driver
- Pliers
- Lubricant part no. 111265; see **Kits and Accessories**, page 37, to order
- Compatible Solvent

Disassembly

1. Follow the **Pressure Relief Procedure**, page 14.
2. Unscrew the four screws (17) and remove the gun from the manifold.
3. Unscrew the air cap retainer (8). Remove the air cap (30) and spray tip (9). See FIG. 17.

Model 26B573: Unscrew the air cap (30). Remove the RAC spray tip (9) and RAC housing (11). See **Parts**, page 26.

4. Inspect the tip gasket (9a) in place. If damaged, replace the tip seal.

5. Remove the cap (27) from the piston housing (1). Remove the springs (28 and 29).
6. Using the supplied wrench (38), loosen the fluid needle setscrew (19). Remove the needle stop (21).
7. Trigger the gun (or remove cap (27) and springs (28, 29)) to pull the needle housing off the seat while you unscrew the diffuser (10) from the gun body (1).
8. Unscrew the needle assembly (14) and use 5/16 in. nut driver to pull the assembly straight out the front of the gun.

NOTICE

Be sure to keep the needle straight when removing it from the gun. If the needle is bent, it must be replaced.

9. Remove the piston. Using a pliers, pull the piston (20) out of the piston housing (1). See FIG. 16.
10. If gasket (15) needs to be replaced, unscrew the two screws (18) and separate the fluid housing (2) and piston housing (1). Inspect gasket (16) and replace if needed.

NOTE: The gasket (16) is attached to assembly with adhesive; therefore, if you are replacing gasket (16), ensure that a replacement gasket is available.

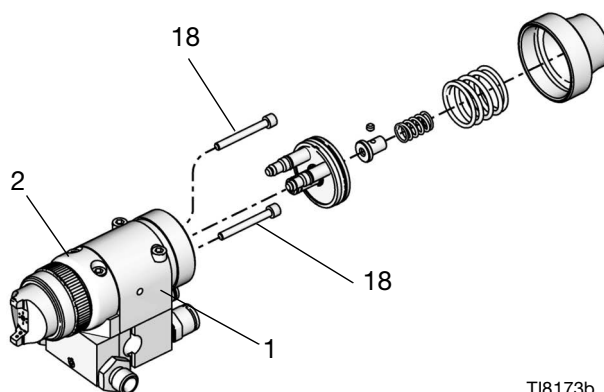

T18173b

FIG. 16: Gasket repair

11. Remove the large o-ring (22) from the piston and the smaller o-ring (23) from the piston shaft. Remove the two o-rings (25, 26) from each of the piston stems. Check that the stems are solidly in place. If they are loose, replace the entire piston assembly (20).

b. *Guns in a circulating system:* Remove the gasket (4) from the fluid housing (2).

13. Clean all parts and replace any worn parts. When assembling, lubricate the threads with anti-seize lubricant.

12. Perform the following applicable step:

a. *Guns in a non-circulating system:* Remove the fluid outlet port plug (5) and gasket (4) from the fluid housing (2). Remove the o-ring (6) and backup o-ring (7) from the plug.

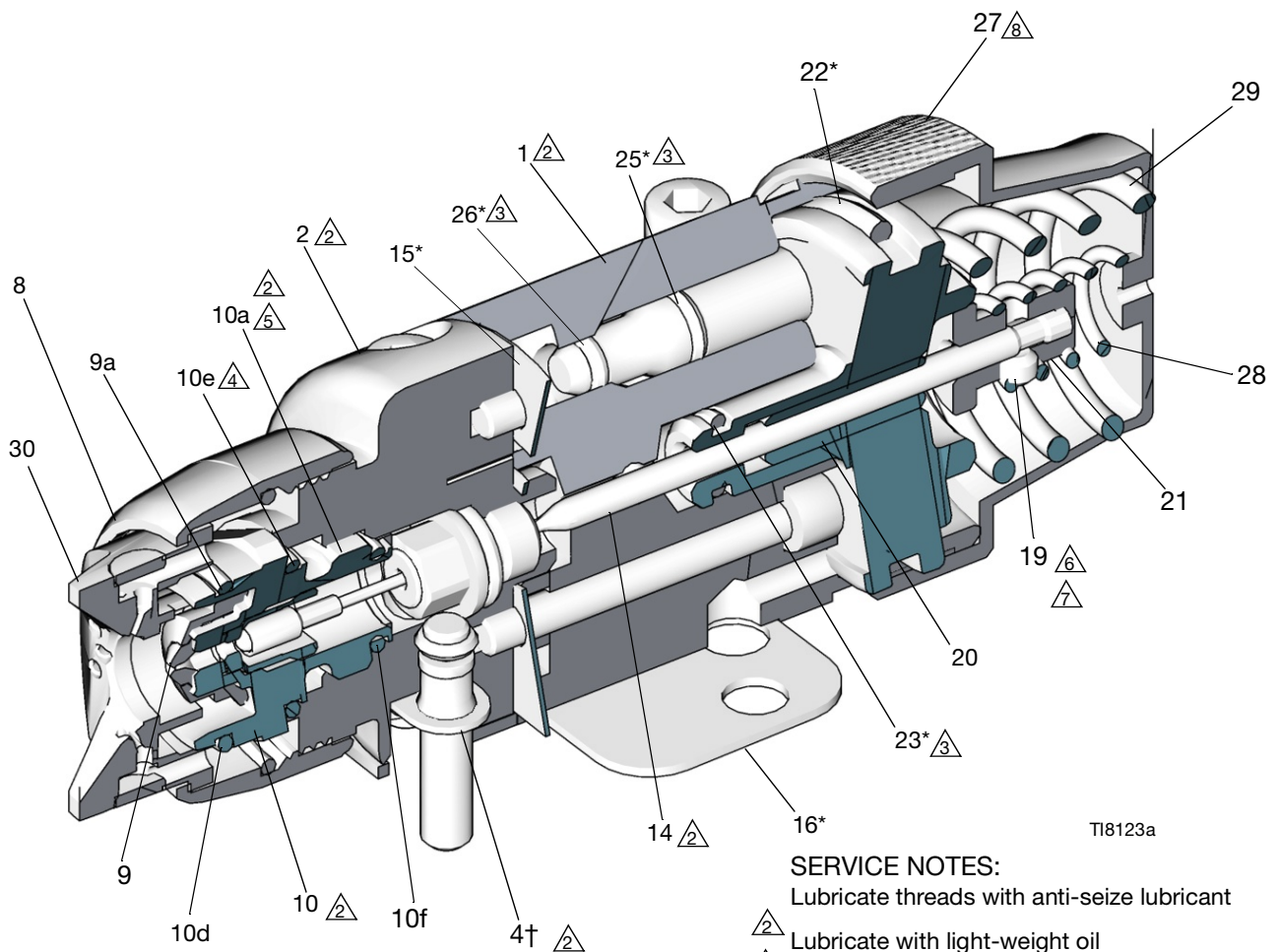

* included with the 288171 Air Seal Repair Kit
 † included with the 288136 Fluid Repair Kit

SERVICE NOTES:

Lubricate threads with anti-seize lubricant

- △2 Lubricate with light-weight oil
- △3 Do not lubricate
- △4 Torque to 155-165 in-lb (18-19 N•m)
- △5 Apply semi-permanent anaerobic sealant
- △6 Torque to 4-5 in-lb (0.45-0.56 N•m)
- △7 Tighten cap (27) until it bottoms out
- △8

Fig. 17: Model 26B572 cutaway view

Diffuser Seat Replacement

Clean parts with a solvent that is compatible with the parts and the fluid being sprayed. See **Kits and Accessories**, page 37.

1. Follow the **Pressure Relief Procedure**, page 14.
2. Remove gun from manifold.
3. Remove the air cap retaining ring (8), air cap (30), and spray tip (9).
4. Trigger the gun (or remove cap (27) and springs (28, 29)) to pull the needle housing off the seat while you unscrew the diffuser (10) from the gun body (1).
5. Inspect the o-rings (10d, 10e, 10f) in place. Carefully remove the o-rings from the diffuser housing (10) and replace if necessary.
6. Remove the seat nut (10c), seat (10b) and seat gasket (10g) (Carbide seat only) using a 7/32 in. hex wrench.
7. Inspect the seat (10b) and seat gasket (10g) and replace if necessary.
8. Reinstall the seat gasket (10g) (Carbide seat only), seat (10b), and seat nut (10c). Torque to 45-50 in-lb (5.1-5.7 N•m). Be sure not to overtighten the nut.

NOTE: When reinstalling the carbide seat, the tapered end of the seat (red side) must point toward the gun tip.

The plastic seat, standard in Model 26B572, can be reinstalled in either direction. However, do not reverse the direction of the seat if it is worn; it must be replaced.

Reassembly

1. **Guns in a Non-circulating only:** Lubricate the backup o-ring (7†) and o-ring (6†) and install them on the fluid outlet port plug (5). Install the plug in the fluid outlet port of the fluid housing (2). See FIG. 1.
2. **All guns:** Reinstall the gasket (4) in the fluid housing (2).
3. Install the o-rings (22, 23) on the piston (20). Install two o-rings (25, 26) on each of the piston stems. Lubricate all the o-rings, the piston, and the piston stems.

4. Align the gasket (15) as shown in the exploded view in Fig. 8.

If replacing gasket (15), place the gasket on the piston housing (1), then install the fluid housing (2). Torque the two screws (18) to 30 in-lb (3.4 N•m)

5. Insert the piston (20) into the piston housing (1).
6. Remove the protective paper from the sticky side of the gasket (16) and adhere the gasket to the bottom of the piston housing (1), making sure the three holes in the gasket are properly aligned with the matching holes in the housing.

NOTICE

Be sure to keep the needle straight when installing it in the piston housing. If the needle is bent it must be replaced.

7. Insert the needle assembly (14) into the front of the fluid housing (2). Tighten to 50-60 in-lb (5.7-6.8 N•m).
8. Lubricate the threads of the diffuser-seat (10). Screw it into the fluid housing (2) and torque to 65 in-lb (7.3 N•m).
9. Install the needle stop (21) on the needle. Coat the setscrew (19) with semi-permanent anaerobic sealant and install the screw into the needle stop. Torque to 4-5 in-lb (0.45-0.56 N•m). Pull on the needle to make sure it seats fully.
10. Install the springs (28, 29).
11. Lubricate the threads of the piston housing (1). Screw the cap (27) onto the housing until it bottoms out.
12. Assemble the standard tip and air cap.

Model 26B573: Install the RAC housing (11) and RAC spray tip (9) in the RAC air cap assembly (30). Position the blue tip guard as desired and screw the air cap assembly onto the gun until it bottoms out. See **Reverse-A-Clean® (RAC) Spray Tip Setup**, page 13.

13. Reinstall the gun on the manifold with the four screws (17). Torque to 65 in-lb (7.3 N•m).

Spray Tip Gasket Replacement

Replace the AXP or AXF spray tip gasket (9a) with a compatible replacement part. See **AXP and AXF Spray Tip Gasket Assembly and Kits**, page 33. Follow the **Reverse-A-Clean® (RAC) Spray Tip Setup**, page 13 to replace RAC spray tip parts.

NOTE: Some AXP spray tip gaskets have a filter. See **Spray Tip Selection Charts**, page 32.

1. Follow the **Pressure Relief Procedure**, page 14.
2. Separate the spray tip (9) from the gun. See **Install a Spray Tip and Air Cap**, page 11.
3. Use a pick to remove the gasket (9a) from the spray tip (9).

4. Press the replacement gasket (9a) into the spray tip (9).

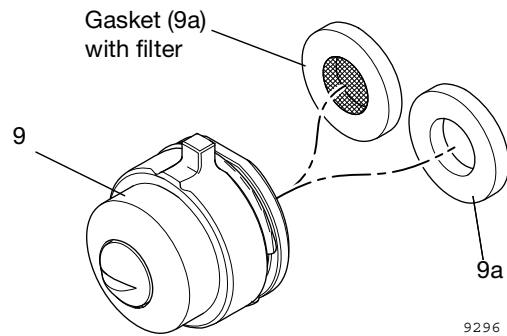
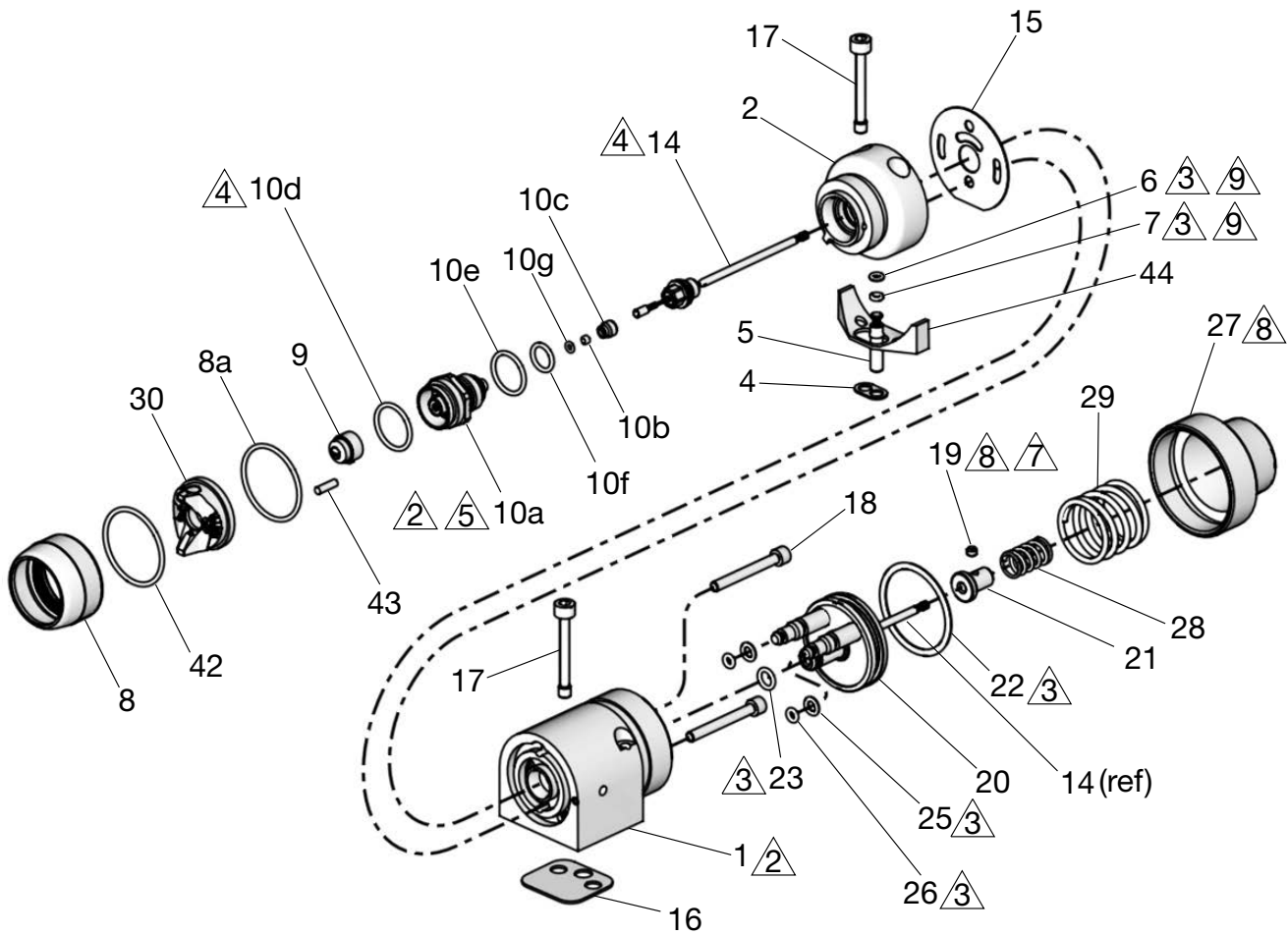

FIG. 18: Spray tip gasket options

5. Install the spray tip (9) and air cap (8). See **Install a Spray Tip and Air Cap**, page 11.

Parts



AA RAC Assembly included with model 26B573 only.

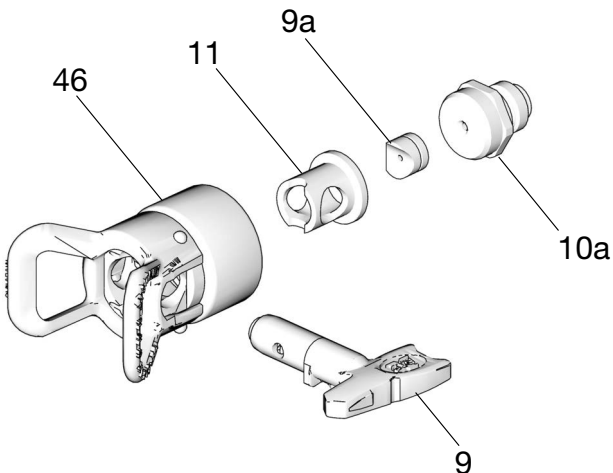

SERVICE NOTES:

- △2 Lubricate threads with anti-seize lubricant
- △3 Lubricate with light weight oil
- △4 Do not lubricate
- △5 Torque to 65 in-lb (7.3 N•M)
- △6 Apply Ssemi permanent anaerobic sealant
- △7 Torque to 4-5 in-lb (0.45 - 0.56 N•M)
- △8 Tighten cap (27) until it bottoms out
- △9 Used on non circulating guns only

Ref. No.	Part No.	Description	Qty.
1	—	BODY	1
2	—	HOUSING, fluid, SST	1
4	288200	GASKET, fluid, plastic homopolymer, pack of 10	2
5	192687	PLUG, fluid, internal, SST	1
6❖	114244	PACKING, o-ring, fluoroelastomer	1
7❖	114340	RING, back-up, PTFE	
8	249134	RING, retaining, assy	1
8a	109213	O-RING, PTFE (see Kit 253032, p. 37, for pack of 5)	1
9	—	SPRAY TIP, Customer's Choice of AXP or AXF, includes tip gasket (9a, not shown), see Spray Tip Selection Charts , page 32 (all models except 26B573)	1
	—	SPRAY TIP, Customer's Choice of LTX or FFLP, includes tip gasket seat assembly (9a), see Spray Tip Selection Charts , page 32 (Model 26B573 only)	
10	288192	DIFFUSER, assy with carbide seat (all models except 26B572 and 26B573)	1
	249132	DIFFUSER, assy, with plastic seat (Model 26B572)	
	249877	DIFFUSER, assy, with RAC seat (Model 26B573)	
10a	—	DIFFUSER, housing	1
10b★❖	—	SEAT	1
10c★❖	—	NUT, seat	1
10d❖	111116	PACKING, o-ring, seat; PTFE	1
10e	109450	PACKING, o-ring; PTFE	1
10f❖	111457	PACKING, o-ring; PTFE	1
10g★	15F409	GASKET, seat (Diffuser assy with carbide seat only)	1
11	15J770	HOUSING, RAC (Model 26B573 only)	1
14	288190†	NEEDLE, assy, kit SST ball (model 26B572 only)	1
	288191‡	NEEDLE, assy, kit, carbide ball (all models except 26B572)	
15✓	15H316	GASKET, polyethylene (front)	1
16✓	114134	GASKET, polyethylene (bottom)	1
17	15H317	SCREW, mounting manifold (M5)	4
18	15H318	SCREW, SHCS	4
19	114137	SCREW, set; 6-32, 1/8 in. long	1
20	240895	PISTON, assy	1

Ref. No.	Part No.	Description	Qty.
21	192452	STOP, needle, SST	1
22✓	115066	PACKING, o-ring, fluoroelastomer	1
23✓	111450	PACKING, o-ring, fluoroelastomer	1
25✓	112319	PACKING, o-ring, fluoroelastomer	2
26✓	111504	PACKING, o-ring, fluoroelastomer	2
27	192453	CAP, piston	1
28	114138	SPRING, compression	1
29	114139	SPRING, compression	1
30	2GF042	CAP, AIR, assy, general finishing (model 26B570 and 26B572)	1
	2WL042	CAP, AIR, assy, lacquer (model 26B571)	
	249478	CAP, AIR, assy, RAC (model 26B573)	
	2LV042	CAP AIR, assy, low viscosity (model 26B574)	
	2WB042	CAP AIR, assy, waterborne (model 26B575)	
	2QD042	CAP AIR, assy, quick dry (26B576)	
	2HV042	CAP, AIR, assy, high viscosity (model 26B577)	
38	114141	WRENCH, hex (not shown)	1
42	15G320	WASHER, PTFE, 1.2 in. O.D. (see Kit 253032, p. 37, for pack of 5)	1
43	15G618	PIN, locating, threaded (all models except 26B572 and 26B573)	1
44	15H702	INSERT, plastic	1
46	249478	GUARD, RAC, (Model 26B573 only)	1
26▲	222385	LABEL, SAFETY, WARNING, MED. ALERT, not shown	1

▲ Replacement safety labels, tags, and cards are available at no cost.

† **SST Needle Assembly, 288190** page 39

‡ **Carbide Needle Assembly, 288191** page 39

❖ **Fluid Seal Repair Kit, 288136** page 40

✓ **Air Seal Repair Kit, 288171** page 40

★ **Carbide Seat Kit, 249456** page 40

❖ **Plastic Seat Kit, 249424** page 40

Compatible Air Assist Manifolds

Manifolds are not included with spray gun. Purchase separately.

Side Fluid Port Manifold

Model 288217 (North America)
Model 288218 (international)

△ Apply anti-seize lubricant (222955) to threads and mating faces of manifold (101) and any fittings and/or plugs used in fluid ports.

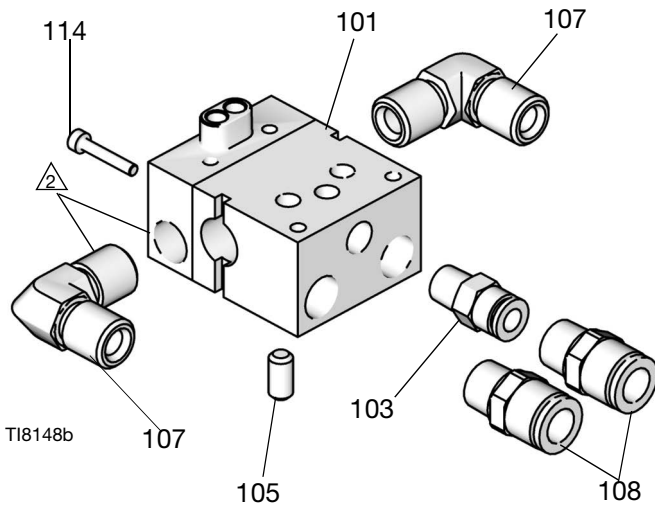

Model 288217 (North America)
Model 288218 (international)

Ref. No.	Part No.	Description	Qty
101	---	MANIFOLD, side fluid ports	1
103	120388	FITTING, tube, air inlet; 1/4 in. OD tube x 1/8 npt(m) (model 288217 only)	1
	120538	FITTING, tube, air inlet; 6 mm OD tube x 1/8 npt(m) (model 288218 only)	
105	114246	SCREW, set; 5/16;0.437 in. long	1
107	114342	ELBOW, street, 1/4 in. npt (model 288217 only)	1
	114247	FITTING, elbow, male; #5 JIC x 1/4 npt (model 288218 only)	
108	120389	FITTING, tube, air line; 3/8 in.OD tube x 1/4 npt (model 288217 only)	2
	120537	FITTING, tube, air line; 8 mm OD tube x 1/4 npt (model 288218 only)	
109*	101970	PLUG, pipe, SST; 1/4-18 ptf, supplied to plug fluid outlet port in non-circulating applications	3
114	120453	SCREW, SCHS, M3 x 18	1

* Not shown.

Bottom Port Manifold

Model 288221

⚠ Apply anti-seize lubricant (222955) to threads and mating faces of manifold (101) and any fittings and/or plugs used in fluid ports.

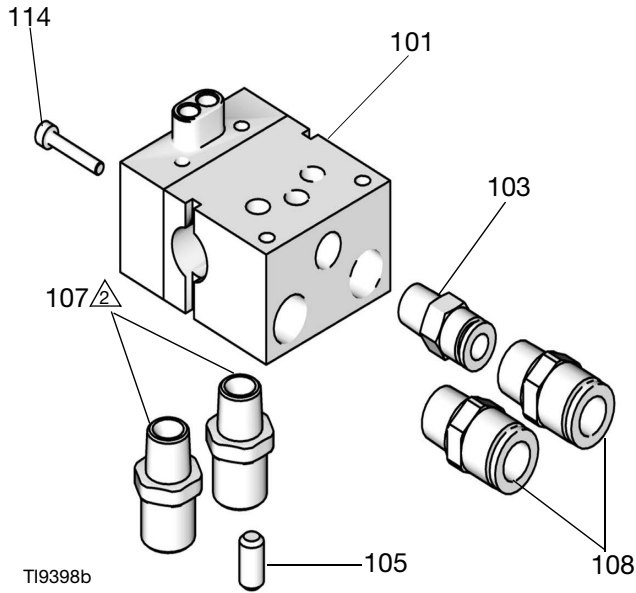

Model 288221

Ref. No.	Part No.	Description	Qty
101	---	MANIFOLD, bottom fluid ports	1
103	120388	FITTING, tube, air inlet; 1/4 in. OD tube x 1/8 npt(m)	1
105	114246	SCREW, set; 5/16; 0.437 in. long	1
107	166846	NIPPLE, SST; 1/4 npsm, straight pipe thread x 1/4 npt	2
108	120389	FITTING, tube, air line; 3/8 in. OD tube x 1/4 npt	2
109*	101970	PLUG, pipe, SST; 1/4-18 ptf, supplied to plug fluid outlet port in non-circulating applications	1
114	120453	SCREW, SCHS, M3 x 18	1

* Not shown.

High Pressure, Side Fluid Port Manifold

Model 288224 (North America)
Model 24C343 (International)

High pressure air assist manifold with side fluid ports and fan adjustment valve.

△2 Apply anti-seize lubricant (222955) to threads and mating faces of manifold (101) and any fittings and/or plugs used in fluid ports.

△3 Install with valve turned fully counterclockwise to outermost position.

△4 Torque to 125-135 in-lb (14-15 N•m).

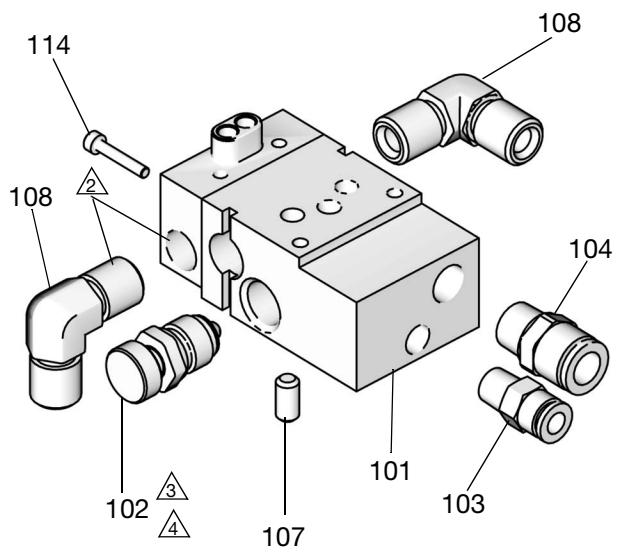

TI0556b

Model 288224 (North America)
Model 24C343 (International)

Ref. No.	Part No.	Description	Qty
101	----	MANIFOLD, fan adjustable	1
102	244029	VALVE, fan, assy.	1
103	120388	FITTING, tube, air inlet 1/4 in. OD tube x 1/8 npt(m) (Model 288224 only)	1
	120538	FITTING, tube, air inlet 6 mm OD tube x 1/8 npt(m) (Model 24C343 only)	
104	120389	FITTING, tube, air line, 3/8 in. OD tube x 1/4 npt (Model 288224 only)	1
	120537	FITTING, tube, air line, 8 mm OD tube x 1/4 npt (Model 24C343 only)	
	15D916*	FITTING, tube, air line, 4 mm OD tube x 1/4 npt; shipped loose (Model 24C343 only)	
107	114246	SCREW, set; 5/16; 0.437 in. long	1
108	114342	ELBOW, male, 1/4 - 18 npt (Model 288224 only)	2
	114247	ELBOW, male, #5 JIC x 1/4-18 npt (Model 24C343 only)	
109*	101970	PLUG, pipe, SST; 1/4-18 ptf, supplied to plug fluid outlet port in non-circulating applications	1
114	120453	SCREW, SCHS, M3 x 18	1

* Not shown, optional size.

Rear Port Manifold

288160 (North America)
288211 (International)

△1 Apply sealant to threads and mating faces of manifold (101) and any fittings and/or plugs used in fluid ports.

△2 Torque to 30-42 in-lb (3.4-4.7 N•m).

△3 Torque to 110-130 in-lb (12.3- 14.7 N•m).

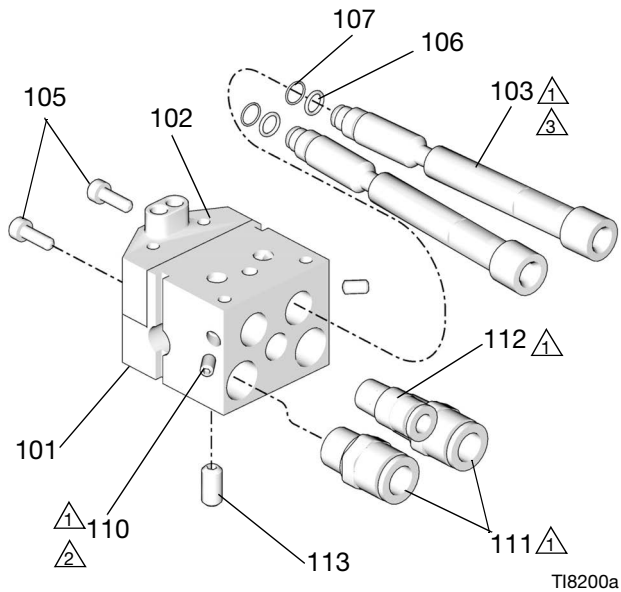

288160 (North America)
288211 (International)

Ref. No.	Part No.	Description	Qty
101	---	MANIFOLD, aluminum	1
103	15H521	FITTING, fluid path, 1/4 npsm (model 288160 only)	2
	15J003	FITTING, fluid path, #5 JIC (model 288211 only)	
105	116475	SCREW, SHCS, M4 x 12	2
106	120353	O-RING, PTFE	2
107	15J077	O-RING, PTFE	2
110	103253	SCREW, set	2
111	120389	FITTING, tube, air line; 3/8 in.OD tube x 1/4 npt (model 288160 only)	2
	120537	FITTING, tube, air line; 8 mm OD tube x 1/4 npt (model 288211 only)	
112	120388	FITTING, tube, air inlet; 1/4 in. OD tube x 1/8 npt(m) (model 288160 only)	1
	120538	FITTING, tube, air inlet; 6 mm OD tube x 1/8 npt(m) (model 288211 only)	
113	114246	SCREW, set, hex soc	1

Spray Tip Selection Charts



To reduce the risk of injury, including skin injection:

- Follow the **Pressure Relief Procedure**, page 14, before removing or installing a spray tip or air cap.
- Never exceed the maximum working fluid pressure for your gun model.

AXP Series Precision Spray Tips (AXPxxx): AXP tips are single orifice spray tips with precise pattern sizes for automatic spray applications.

AXF Fine Finish Pre-Orifice Spray Tips (AXFxxx): AXF tips have a pre-orifice that assists in atomizing shear thinning materials, including lacquers.

Order desired tip (Part No. AXPxxx or AXFxxx) where xxx is the size code for the chart.

AXP Spray Tips

Orifice Size in. (mm)	* Fluid Output, fl oz/min (lpm)		Maximum Pattern Width at 12 in. (305 mm) Pattern Width Tolerance +/- 0.5 in. (13.0 mm)						
	at 600 psi (4.1 MPa, 41 bar)	at 1000 psi (7.0 MPa, 70 bar)	5 (127)	7 (178)	9 (228)	11 (279)	13 (330)	15 (381)	17 (432)
	Size Code (Spray Tip Part No.)								
† 0.009 (0.229)	7.0 (0.2)	9.1 (0.27)	209	309	409	509	---	---	---
† 0.011 (0.279)	10.0 (0.3)	13.0 (0.4)	211	311	411	511	611	---	---
0.013 (0.330)	13.0 (0.4)	16.9 (0.5)	213	313	413	513	613	713	---
0.015 (0.381)	17.0 (0.5)	22.0 (0.7)	215	315	415	515	615	715	815
0.017 (0.432)	22.0 (0.7)	28.5 (0.85)	---	317	417	517	617	717	817
0.019 (0.483)	28.0 (0.8)	36.3 (1.09)	---	---	419	519	619	719	---
0.021 (0.533)	35.0 (1.0)	45.4 (1.36)	---	---	421	521	621	---	---

* Tips are tested in water.

† Tip sizes include a tip gasket with 150 mesh tip filter. See **AXP and AXF Spray Tip Gasket Assembly and Kits**, page 33.

Measured with NO airflow. Air assist will tend to reduce pattern lengths by 1 in. to 2 in.

Fluid output (Q) at other pressures (P) can be calculated by this formula: $Q = (0.041) (QT) \sqrt{P}$ where QT = fluid output (fl oz/min) from the above table for 600 psi.

AXF Spray Tips

Orifice Size in. (mm)	* Fluid Output, fl oz/min (lpm)		Maximum Pattern Width at 12 in. (305 mm) in. (mm)						
	at 600 psi (4.1 MPa, 41 bar)	at 1000 psi (7.0 MPa, 70 bar)	2 to 4 (75)	4 to 6 (150)	6 to 8 (200)	8 to 10 (250)	10 to 12 (300)	12 to 14 (350)	14 to 16 (400)
	Size Code (Spray Tip Part No.)								
0.007 (0.178)†	4.0 (0.1)	5.2 (0.15)	---	---	306	---	---	---	---
0.009 (0.229)†	7.0 (0.21)	8.5 (0.25)	108	208	308	408	508	608	---
0.011 (0.279)†	9.5 (0.28)	12.5 (0.37)	---	210	310	410	510	610	710
0.013 (0.330)	12.0 (0.35)	16.0 (0.47)	---	212	312	412	512	612	712
0.015 (0.381)	16.0 (0.47)	21.0 (0.62)	---	---	314	414	514	614	714
0.017 (0.432)	20.0 (0.59)	26.5 (0.78)	---	---	316	416	516	616	716
0.019 (0.483)	28.0 (0.8)	36.3 (1.09)	---	---	---	---	518	---	---

* Tips are tested in water.

† Tip sizes include a tip gasket with 150 mesh tip filter (115158). See **AXP and AXF Spray Tip Gasket Assembly and Kits**, page 33.

Measured with NO airflow. Air assist will tend to reduce pattern lengths by 1 in. to 2 in.

Fluid output (Q) at other pressures (P) can be calculated by this formula: $Q = (0.041) (QT) \sqrt{P}$ where QT = fluid output (fl oz/min) from the above table for 600 psi.

AXP and AXF Spray Tip Gasket Assembly and Kits

Use a compatible kit to replace the AXP and AXF spray tip gasket. See **Spray Tip Gasket Replacement**, page 25.

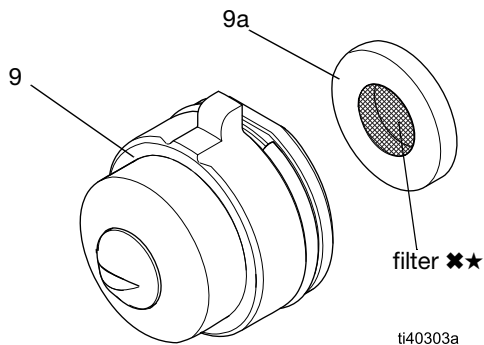

Part Number	Description	Kit	Kit Description
183616	Tip gasket (9a)	26C713	10 pack tip gasket (9a) replacements.
115158**	Tip gasket (9a) with a filter	241804	10 pack replacements of tip gasket (9a) with filter. Compatible with AXP tips.

** Included with AXP tips orifice size .011 and smaller.
 ** Compatible with AXP tips only. Not compatible with AXF tips.

FIG. 19: AXP and AXF Spray Tip Assembly. Tip gasket with a filter (115158†) shown.

Reverse-A-Clean (RAC) Spray Tips

Order desired tip (Part No. LTXxxx, FFLPxxx, or WRxxxx) where xxx is the size code from the chart.

LTX and FFLP RAC Spray Tips

Orifice Size in. (mm)	* Fluid Output 2000 psi (14.0 MPa, 140 bar) fl oz/min (lpm)	Maximum Pattern Width at 12 in. (305 mm) in. (mm)							
		2 to 4 (100)	4 to 6 (150)	6 to 8 (200)	8 to 10 (250)	10 to 12 (300)	12 to 14 (350)	14 to 16 (400)	16 to 18 (450)
		Size Code (Spray Tip Part No.)							
LTX RAC Spray Tips (LTX)									
0.009 (0.229)	11.2 (0.33)	109	209	309	409	509	---	---	---
0.011 (0.279)	16.6 (0.49)	111	211	311	411	511	611	---	---
0.013 (0.330)	23.3 (0.69)	---	213	313	413	513	613	---	---
0.015 (0.381)	30.8 (0.91)	115	215	315	415	515	615	---	---
0.017 (0.432)	39.5 (1.17)	---	217	317	417	517	617	---	817
0.019 (0.483)	49.7 (1.47)	---	219	319	419	519	619	---	819
0.021 (0.533)	60.5 (1.79)	---	221	321	421	521	621	721	821
0.023 (0.584)	72.7 (2.15)	---	---	323	423	523	623	723	---
0.025 (0.635)	85.9 (2.54)	---	225	325	425	525	625	---	---
0.027 (0.686)	100.0 (2.96)	---	227	327	427	527	627	---	827
0.029 (0.737)	115.6 (3.42)	---	---	329	429	529	629	729	---
0.031 (0.787)	131.8 (3.90)	---	231	331	431	531	631	---	831
0.033 (0.838)	149.4 (4.42)	---	---	---	433	533	633	---	833
0.035 (0.889)	168.4 (4.98)	---	235	335	435	535	635	735	835
Fine Finish Low Pressure RAC Spray Tips (FFLP)									
0.008 (0.203)	8.8 (0.26)	108	208	308	---	---	---	---	---
0.010 (0.254)	13.9 (0.41)	110	210	310	410	510	---	---	---
0.012 (0.305)	19.9 (0.59)	112	212	312	412	512	612	---	---
0.014 (0.356)	27.0 (0.80)	---	214	314	414	514	614	---	---
0.016 (0.406)	35.0 (1.04)	---	---	---	---	516	616	---	---

*Tips are tested in water.

Measured with NO airflow. Air assist will tend to reduce pattern lengths by 1 in. to 2 in.

Fluid output (Q) at other pressures (P) can be calculated by this formula: $Q = (0.041) (QT) \sqrt{P}$ where QT = fluid output (fl oz/min) from the above table for the selected orifice size.

Wide (WR) RAC Spray Tips

Orifice Size in. (mm)	* Fluid Output fl oz/min (lpm) 2000 psi (14.0 MPa, 140 bar)	Maximum Pattern Width at 12 in. (305 mm)
		24 in. (610 mm)
		Size Code (Spray Tip Part No.)
0.021 (0.533)	60.5 (1.79)	1221
0.023 (0.584)	72.7 (2.15)	1223
0.025 (0.635)	85.9 (2.54)	1225
0.027 (0.686)	100.0 (2.96)	1227
0.029 (0.737)	115.6 (3.42)	1229
0.031 (0.787)	131.8 (3.90)	1231
0.033 (0.838)	149.4 (4.42)	1233
0.035 (0.889)	168.3 (4.98)	1235
0.037 (0.940)	187.9 (5.56)	1237
0.039 (0.991)	208.9 (6.18)	1239

*Tips are tested in water.

Measured with NO airflow. Air assist will tend to reduce pattern lengths by 1 in. to 2 in.

Fluid output (Q) at other pressures (P) can be calculated by this formula: $Q = (0.041) (QT) \sqrt{P}$
 where QT = fluid output (fl oz/min) from the above table for the selected orifice size.

RAC Spray Tip Assembly and Kits

RAC spray tips include a metal fluid seat and rubber tip gasket. RAC conversion kits are available. See **RAC Conversion Kit 287917**, page 37.

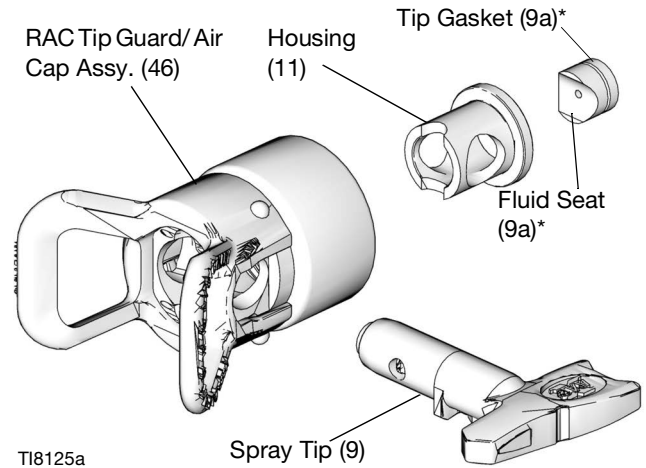

* Tip gasket seat assembly (9a) is included with the spray tip (9).

FIG. 20: RAC spray tip assembly

RAC Spray Tip Gasket Seat Parts

Part Number	Part Description	Included with RAC Spray Tip
15A981	Fluid seat	LTX and WR
15A978	Tip gasket, fluoroelastomer	LTX and WR.
15E557★	Acetal tip gasket	FFLP
15A978	Tip gasket, fluoroelastomer	FFLP
17M575	Fluid Seat	FFLP
248936	Five pack of fluid seats (15A981) and five pack of acetal tip gaskets (15E936)	-----

★Compatible with LTX and WR RAC spray tips. Purchase Kit 248936.

Air Cap Selection Chart

based on coating properties and finishing requirements.

				
<p>To reduce the risk of injury, including skin injection, follow the Pressure Relief Procedure, page 14, before removing or installing a spray tip and/or air cap.</p>				

Air caps are versatile, and more than one air cap can meet your finishing requirements. Select an air cap

Air Cap Part No.	Air Cap	Color	Optimal Use Recommendations
2WB042	Waterborne (WB)	Blue	Break up the waterborne fluid stream for even wet film build with waterborne materials.
2HV042	High Viscosity (HV)	Blue Grey	Build wet film with high solids materials.
2LV042	Low Viscosity (LV)	Silver	Promote dispersion of low viscosity materials.
2QD042	Quick Drying (QD)	Green	Maintain transfer efficiency and minimize air bubbles with quick drying materials.
2GF042	General Finishing (GF)	PTFE Nickel	Atomizes tails at lower pressures.
2WL042	Lacquer (WL)	Black	Spray wood finishing top coats and lacquer.
2TC042	Top Coat (TC)	PTFE Nickel	Spray wood finishing top coats

Kits and Accessories

Gun Manifolds

Order manifolds separately; not included with gun
See **Parts**, page 26.

Part No.	Description
288217	Manifold with side fluid ports (North America)
288218	Manifold with side fluid ports (International)
288221	Manifold with bottom fluid ports (North America)
288224	High Pressure Air Assisted Manifold with side fluid ports and manual fan adjustment valve (North America)
24C343	High Pressure Air Assisted Manifold (International)
288160	Rear port manifold (North America)
288211	Rear port manifold (International)
26D226	Custom Manifold with 1/4 BSPP Male fluid inlet

Manifold Accessories

288197	Retrofit Adapter Plate, enables the manifold to be attached to a variety of bolt patterns.
Temperature Sensor and Cable	
198457	RTD Sensor, 100 ohm, 1/8 npt(m) with 3 pin Picofast connector. For temperature conditioned manifold
198458	RTD cable, 6 ft. (1.83 m) Flex cable to St. Clair connector. For temperature conditioned manifold

Needle/Diffuser Kits

Needles must be used only with the specified diffuser-seat to guarantee proper seating and life.

Part No.	Description
Standard viscosity/standard flow	
288191	Fluid Needle, carbide ball
288192	Diffuser-Seat, carbide seat
Acid catalyzed materials/very low viscosity materials	
288190	Fluid Needle, SST ball
288193	Diffuser-Seat, plastic seat

Air Cap Kits

Part No.	Description	Description
249140	HVLP Air Cap Verification Kit	Use to determine air pressure behind the air cap. Do not use for actual spraying. To be HVLP compliant, the atomizing air pressure must not exceed 10 psi (70kPa, 0.7 bar).
253032	Air Cap Seal Kit	Pack of five seals and five o-rings for the air cap assembly.

Spray Tip Kits

AXP and AXF Spray Tip Gasket Assembly and Kits, page 33

RAC Spray Tip Assembly and Kits, page 35

RAC Conversion Kit 287917

To convert from a gun with standard spray tip, tip guard, and air cap to Part No. 26B573 gun with the AA RAC assembly. See parts list and drawing below for parts included with kit.

Ref. No.	Part No.	Description	Qty.
46	249478	CAP, air, AA RAC, assy	1
11	15J770	HOUSING, RAC	1
9**	LTXxxx	TIP, cylinder; tip of choice; includes item 3a; order separately	2
9a**		TIP GASKET SEAT, assembly	1
10a	249877	SEAT, diffuser	1

Tip (9) is not included with kit; order separately. See **Reverse-A-Clean (RAC) Spray Tips, page 34.

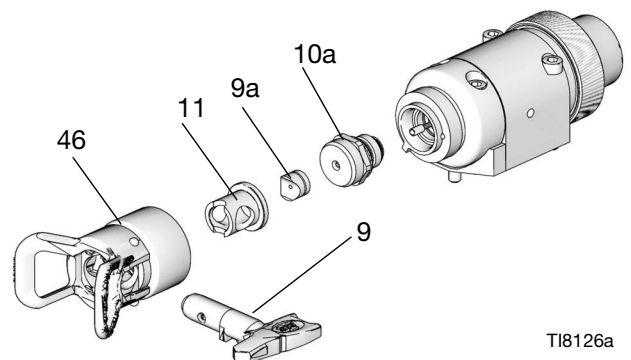

T18126a

Cefla Kit 26D227

Part No.	Description	Qty.
24B609	Adapter Kit	1
26B571**	AA Auto Gun (WL)	1
26B736	Gun Alignment Tool Kit	1
26D226	Custom Manifold	1

Tip is not included with kit; order separately. See **Spray Tip Selection Charts, page 32.

Seat Kits

Part No.	Description	
249424	Plastic Seat Repair Kit	Replacement plastic seat (pack of ten), and seat nut.
287962	SST Seat Repair Kit	Assembled diffuser with SST seat (15H282) for use with pigmented acid catalyzed materials.
249456	Carbide Seat Repair Kit	Replacement carbide seat, seat gasket, and seat nut.

Inline Fluid Filter Kits

Part No.	Part	Description
210500	Inline Fluid Filter, 100 mesh	5000 psi (35 MPa, 350 bar) Maximum Working Pressure. Fits onto the gun fluid connector. 1/4-18 npsm
26C633	Inline Fluid Filter, 60 mesh.	6150 psi (42.4 MPa, 424 bar) Maximum Working. Fits onto the gun fluid connector. 1/4-18 npsm
238563	60 Mesh Inline Fluid Filter Kit	replacement filter element; pack of three
238564	60 Mesh Inline Fluid Filter Kit	Replacement filter element; pack of twenty-five
238561	100 Mesh Inline Fluid Filter Kit	Replacement filters element; pack of three
238562	100 Mesh Inline Fluid Filter Kit	Replacement filter element; pack of twenty-five
25N892	150 Mesh Inline Fluid Filter Kit	Replacement filter element; three pack
25N894	200 Mesh Inline Fluid Filter Kit	Replacement filters element; three pack

Filter Element (part varies by kit)

210501 168517

Carbide Needle Assembly, 288191

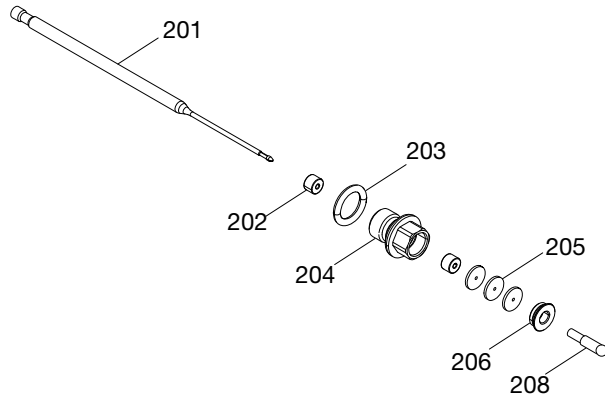

Carbide Needle Assembly, 288191, Parts List

Ref.	Part	Description	Qty.
201	15H454	NEEDLE	1
202	16A019	BEARING, front	1
203	110004	PACKING, O-ring	1
204	16A016	HOUSING, packing, needle, autogun	1
205	16D540	SEAL, large, UHMWPE	1
206	16A018	STOP, packing	3
207*	070270	LUBRICANT, grease	2
208	24U119	HOUSING, ball, brazed	1

* Parts not shown .

SST Needle Assembly, 288190

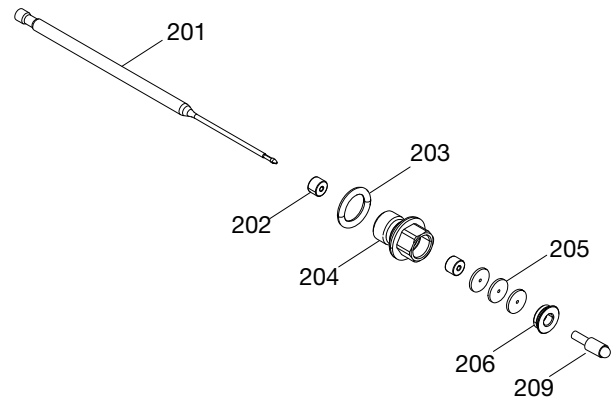

SST needle Assembly, 288190, Parts List

Ref.	Part	Description	Qty.
201	15H454	NEEDLE	1
202	16A019	BEARING, front	1
203	110004	PACKING, O-ring	1
204	16A016	HOUSING, packing, needle, autogun	1
205	16D540	SEAL, large, UHMWPE	1
206	16A018	STOP, packing	3
207*	070270	LUBRICANT, grease	2
209	24U119	BALL, assy, stainless steel	1

* Parts not shown.

Fluid Seal Repair Kit, 288136

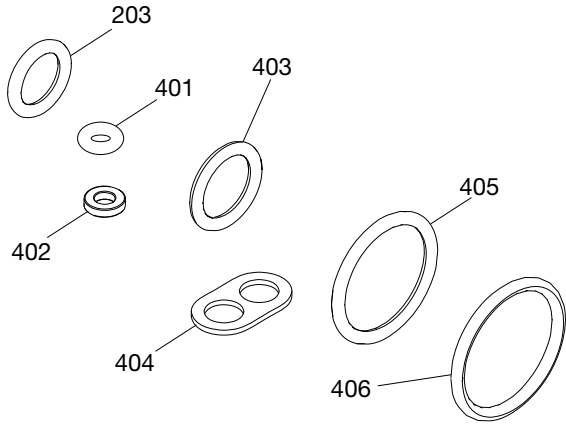

Fluid Seal Repair Kit, 288136, Parts List

Ref.	Part	Description	Qty.
203	110004	PACKING, O-ring	1
401	114244	PACKING, O-ring	1
402	114340	RING, back-up, PTFE	1
403	111457	PACKING, O-ring	1
404	192443	GASKET, fluid	1
405	109450	PACKING, O-ring	1
406	111116	PACKING, O-ring, seat	1

Plastic Seat Kit, 249424

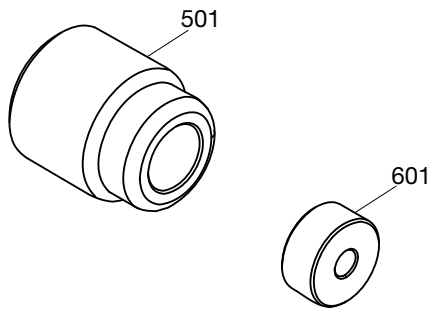

Plastic Seat Kit, 249424, Parts List

Ref.	Part	Description	Qty.
501	15F361	NUT, screw in seat	1
601	15F684	SEAT, delrin, 0.063 in. dia.	1

Air Seal Repair Kit, 288171

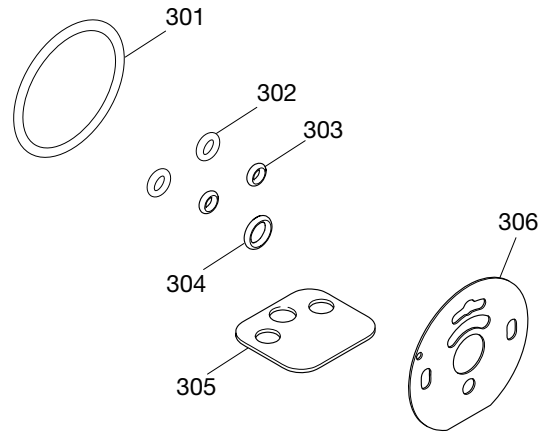

Air Seal Repair Kit, 288171

Ref.	Part	Description	Qty.
301	115066	PACKING, O-ring	1
302	112319	PACKING, O-ring	2
303	111504	PACKING, O-ring	2
304	111450	PACKING, O-ring	1
305	114134	GASKET, polyethylene, bottom	1
306	15H316	GASKET, polyethylene, front	1

Carbide Seat Kit, 249456

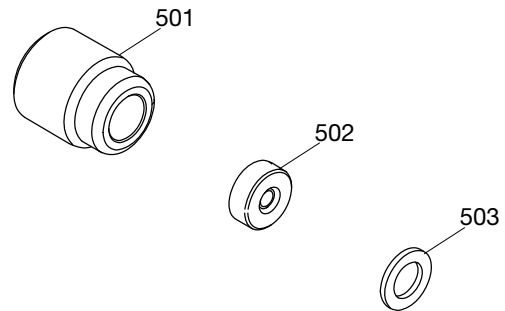

Carbide Seat Kit, 249456 Parts List

Ref.	Part	Description	Qty.
501	15F361	NUT, screw in seat	1
502	277117	SEAT, carbide, 0.063 in. dia.	1
503	15F409	GASKET, seat	1

System Accessories

Part No.	Part	Description
288201	Gasket Filter	Optional 100 mesh filter that can be installed in the fluid inlet gasket (4) for added filtration; pack of ten
26D226	Custom Manifold	Manifold with 1/4 BSPP male fluid inlet

Part No.	Description
222011	Grounding Clamp and Wire
26B736	Gun Alignment Tool Kit
Bleed-type Master Air Valve	
300 psi (2.1 MPa, 21 bar) Maximum Working Pressure Relieves air trapped in the air line between the pump air inlet and this valve when closed	
107141	3/4 npt(m x f) inlet and outlet
107142	1/2 npt(m x f) inlet and outlet
High Pressure Ball Valves, Fluoroelastomer Seals	
5000 psi (34 MPa, 345 bar) Maximum Working Pressure Can be used as fluid drain valve.	
210657	1/2 npt(m)
210658	3/8 npt(m)
210659	3/8 x 1/4 npt(m)
Cleaning Accessories	
15C161	Ultimate Gun Cleaning Kit: brushes and tools for gun maintenance.
249598	Unclogging Needle: picks for unclogging gun tip
101892	Brush for cleaning the gun

Dimensions

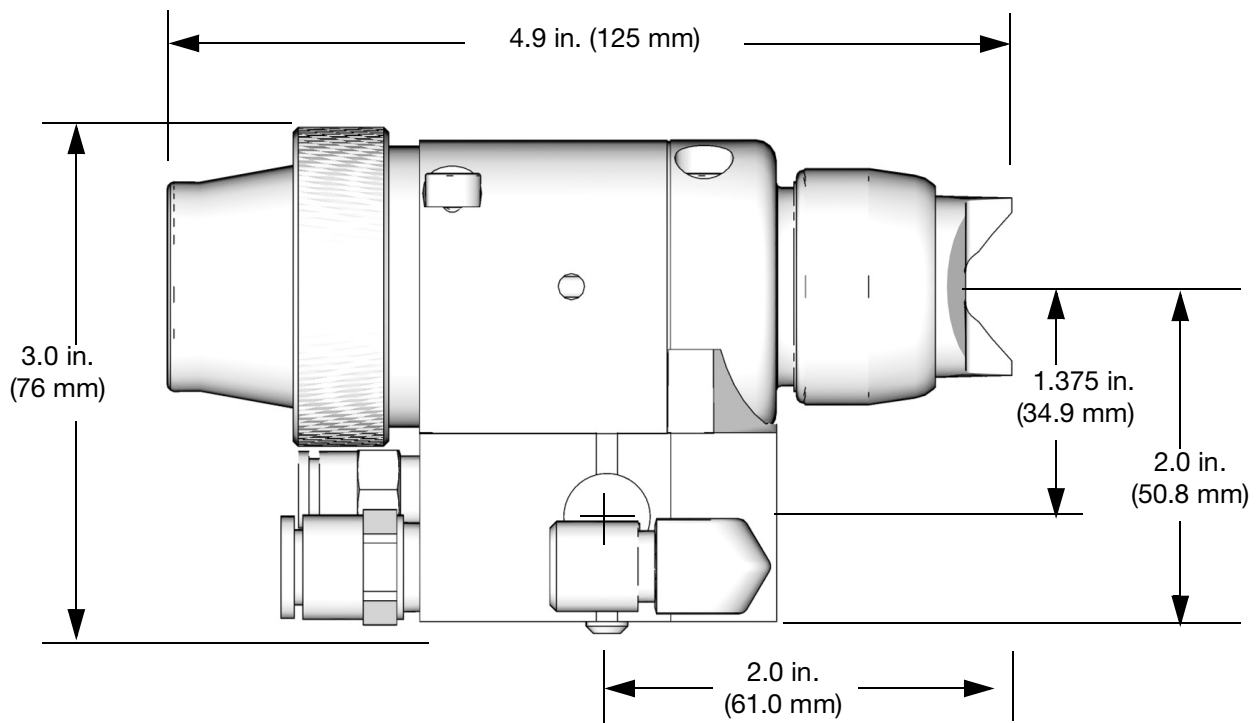
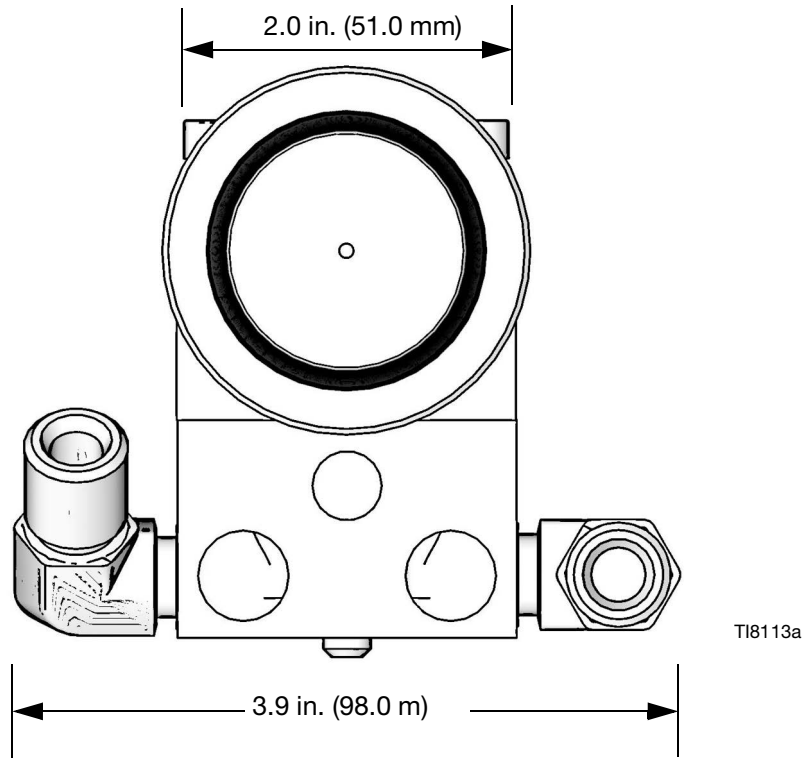

Mounting Hole Layout

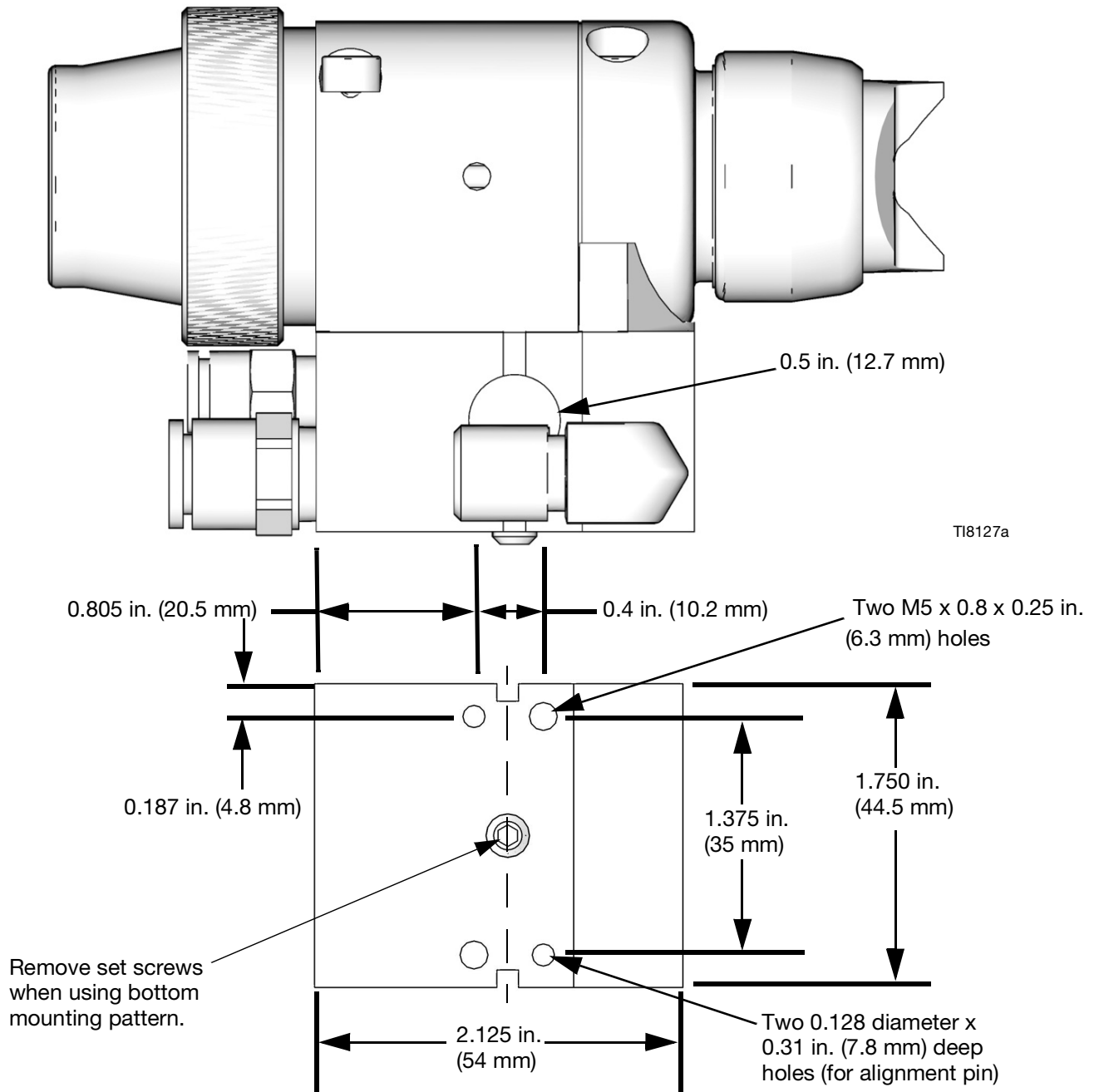

TI8127a

TI8107a

Manifolds

Retrofit Adapter Plate: Model 288197

Retrofit Adapter Plate

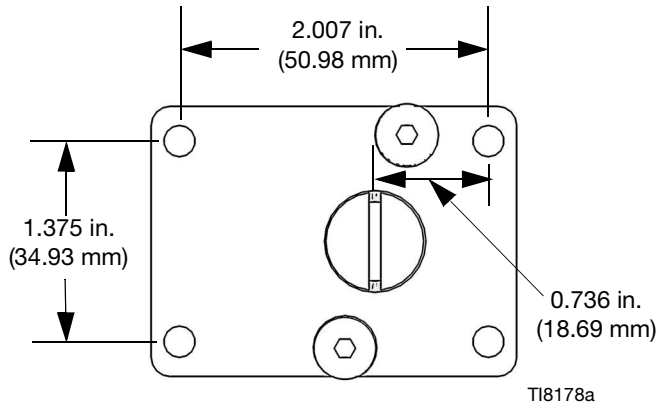

Gun with Retrofit Adapter Plate

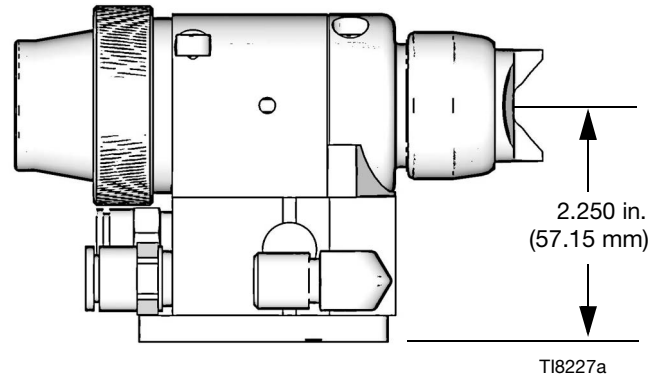

Rear Port Manifold

Model 288160 (North America)

Model 288211 (International)

Rear Port Manifold

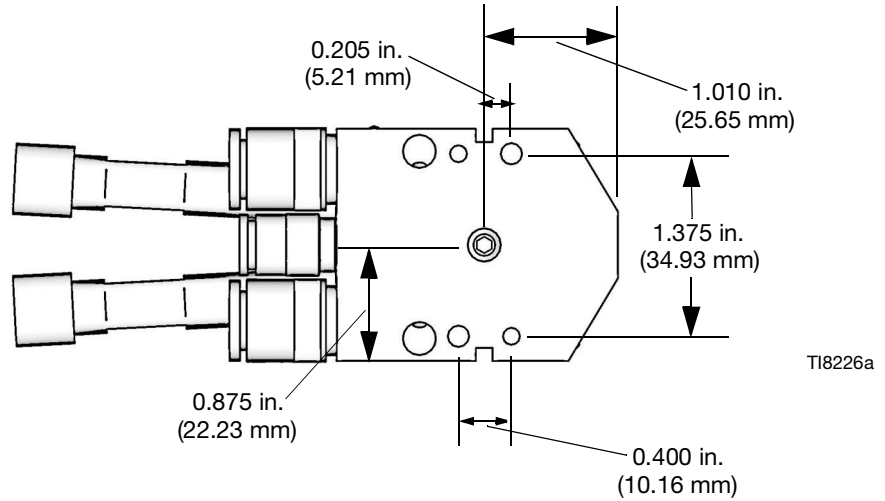

Gun with Rear Port Manifold

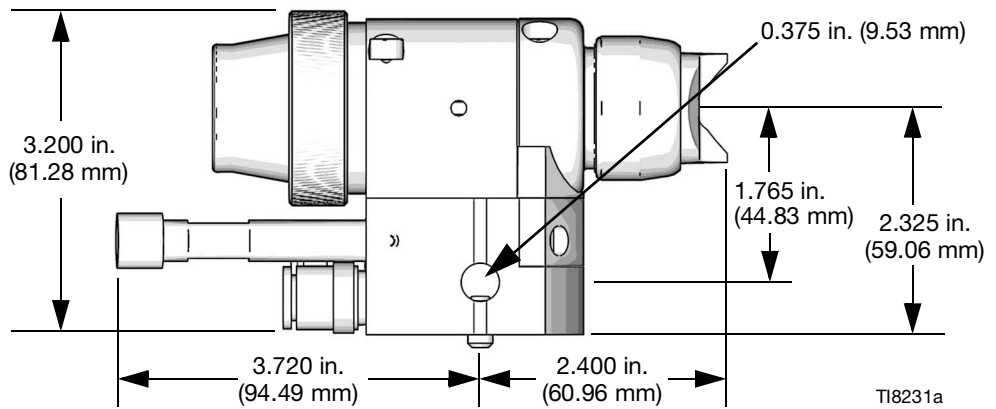

Side Port Manifold

Model 288217 (North America)

Model 288218 (International)

Side Port Manifold

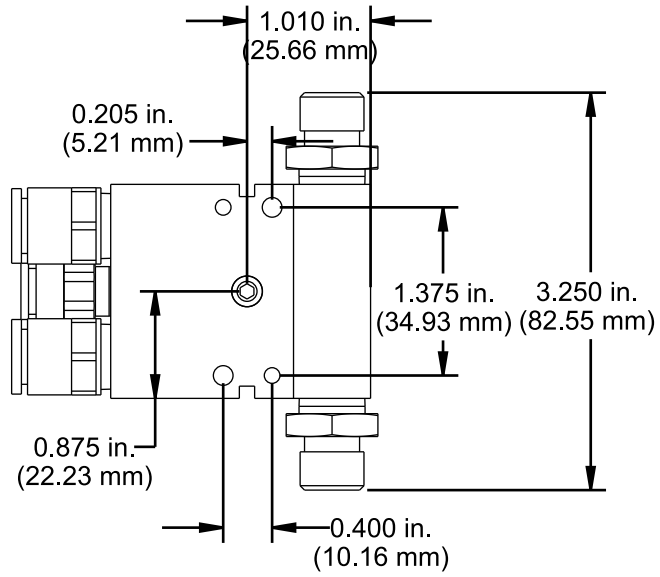

Gun with Side Port Manifold

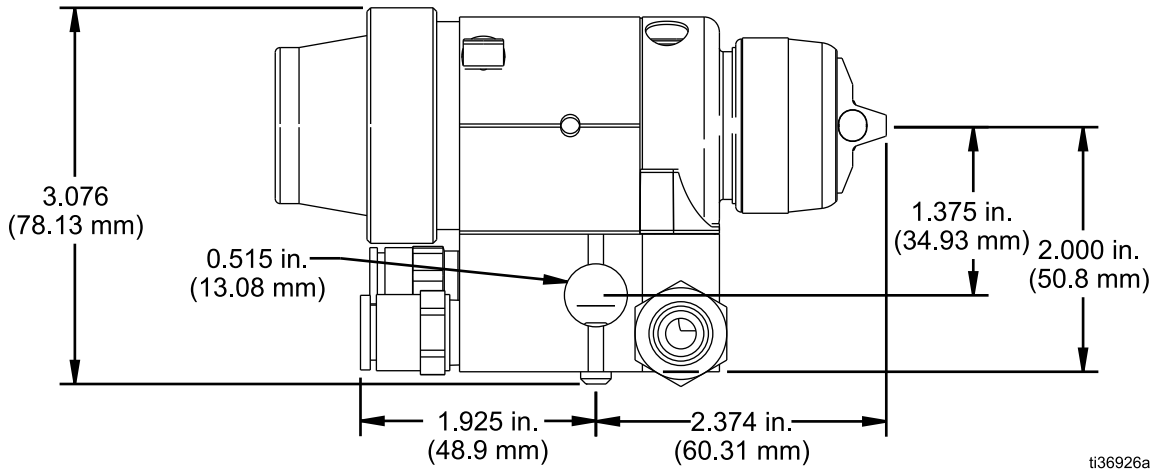

ti36926a

Bottom Port Manifold

Model 288221

Bottom Port Manifold

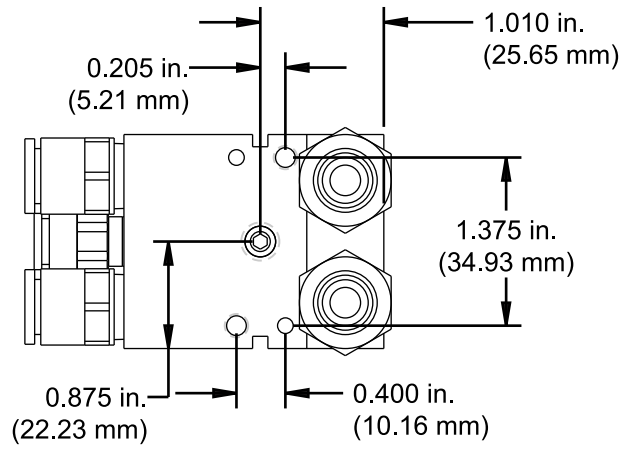

Gun with Bottom Port Manifold

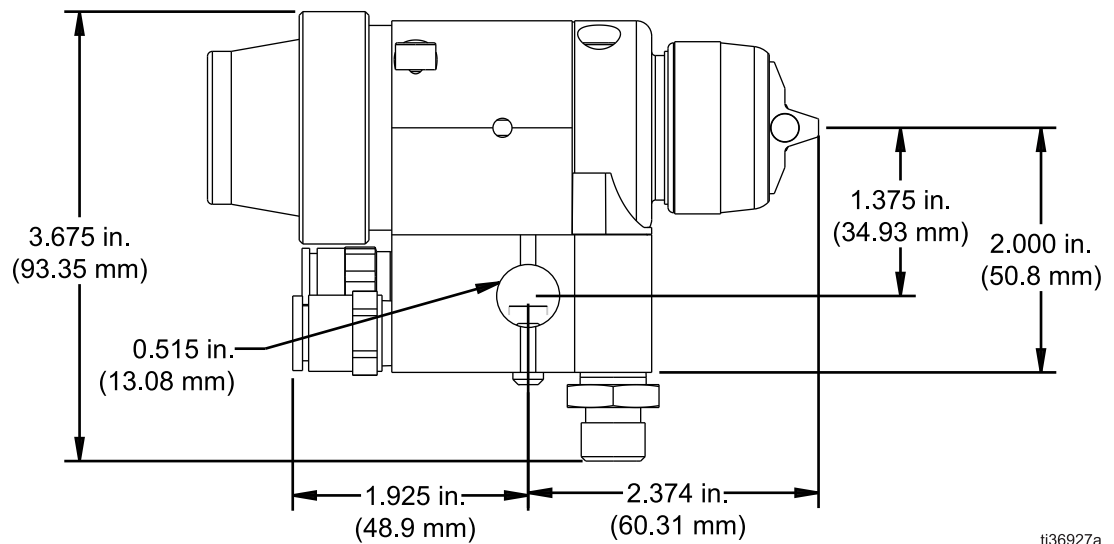

ti36927a

Adjustable Port Manifold

Model 288224 North America

Model 24C343 International

Adjustable Port Manifold

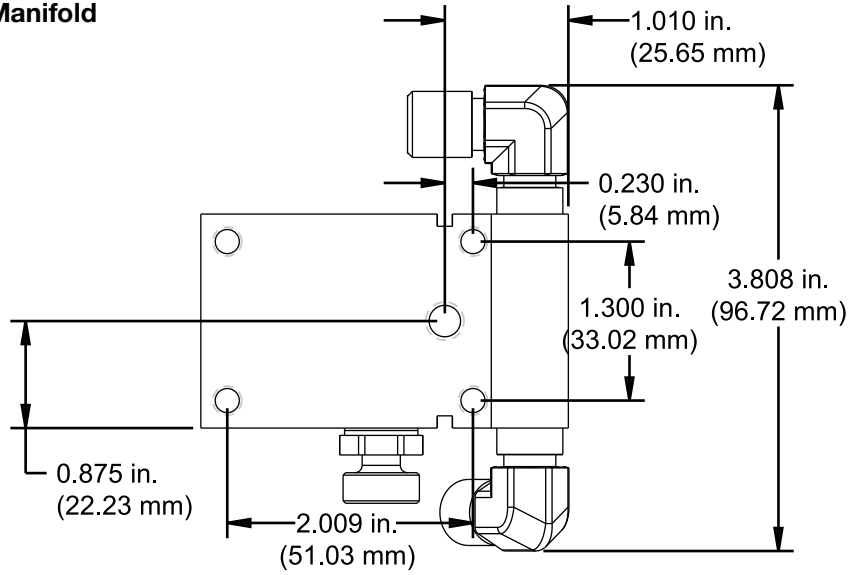

Gun with Adjustable Port Manifold

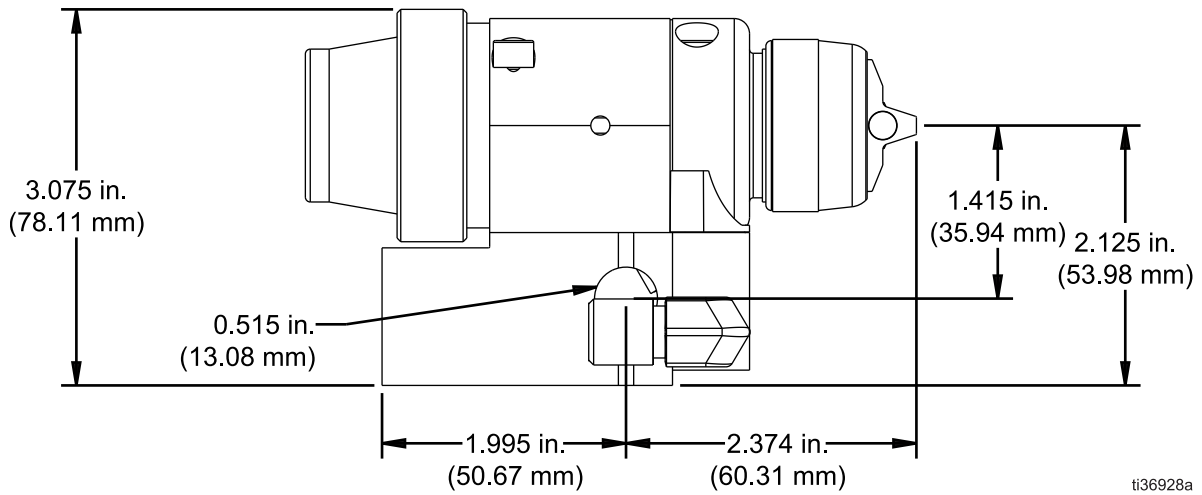

ti36928a

Technical Specifications

PerformAA Auto Air Assist Spray Guns	US	Metric
Maximum working fluid pressure	4000 psi	28 MPa, 280 bar
Maximum working air pressure	100 psi	0.7 MPa, 7 bar
Maximum fluid temperature	120°F	49° C
Minimum Air Cylinder Actuation Pressure	50 psi	0.34 MPa, 3.4 bar
Materials of Construction	Stainless Steel, Carbide, Ultra High Molecular Weight Polyethylene, Chemically Resistant Fluoroelastomer, Engineered Plastic, PTFE, Polyamide	
Weight	1.2 lbs	965 grams

Triggering Speed

These values apply to a new gun with a 6 ft. (1.8 m), 1/4 in. (6.3 mm) OD cylinder air line and a 0.019 in. tip. These values will vary slightly with use and with variations in equipment.

Models (3/16 in. ball)			
Cylinder Air Pressure psi (MPa, bar)	Fluid Pressure psi (MPa, bar)	msec to fully open	msec to fully close
50 (0.34, 3.4)	600 (4.2, 42)	60	60
50 (0.34, 3.4)	1800 (12.4, 124)	60	60
50 (0.34, 3.4)	4000 (28, 280)	60	60

Sound Data (dBa)

Operating Conditions	Fluid Pressure with 0.019 in. tip psi (MPa, bar)	Fan Air Pressure psi (MPa, bar)	Atomizing Air Pressure psi (MPa, bar)	Sound Pressure dB(A)†	Sound Power dB(A)‡
Rated Pressures	4000 (28, 280)	0	100 (0.7, 7)	91.75	91.90
		100 (0.7, 7)	100 (0.7, 7)	91.22	91.46
Normal Operating Pressures	600 (4.2, 42)	0	30 (0.21, 2.1)	83.87	76.28
		30 (0.21, 2.1)	30 (0.21, 2.1)	84.41	78.65

† Sound pressure measured 3.28 feet (1 meter) from equipment.

‡ Sound power measured per ISO-9614-2.

California Proposition 65

CALIFORNIA RESIDENTS

 **WARNING:** Cancer and reproductive harm. – www.P65warnings.ca.gov.

Air Flow

Air caps were tested with a high pressure, air assist manifold (288224) with side fluid ports and a fan adjustment valve.

General Finishing (GF), Wood Lacquer (WL), and Top Coat (TC) Air Caps

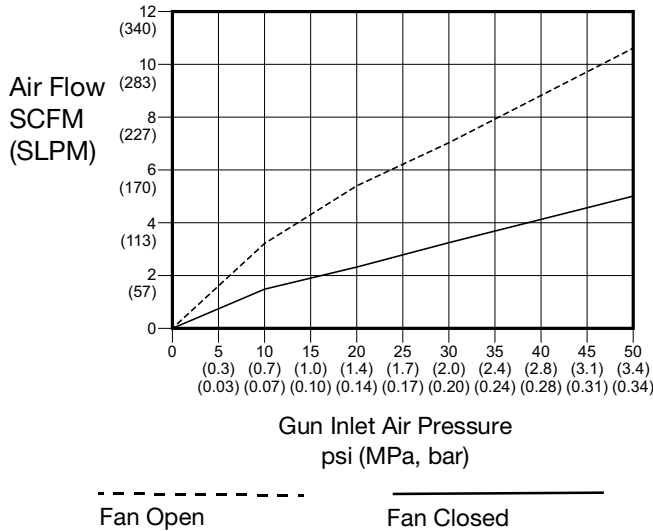

Low Viscosity (LV) and Waterborne (WB) Air Caps

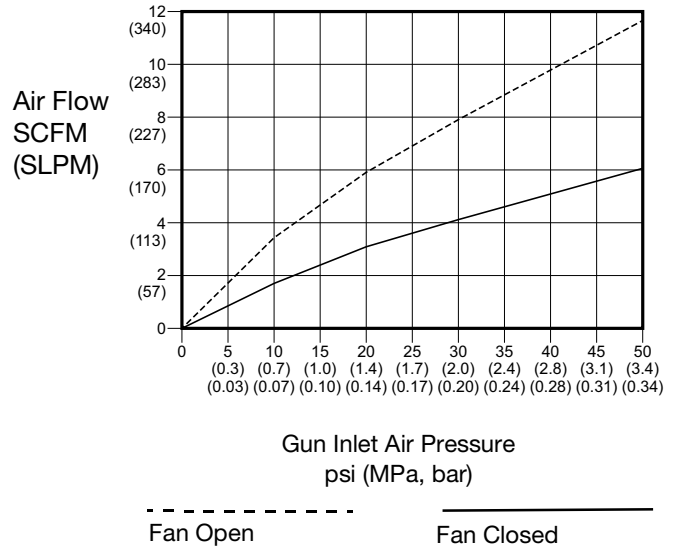

Quick Drying (QD) and High Viscosity (HV) Air Caps

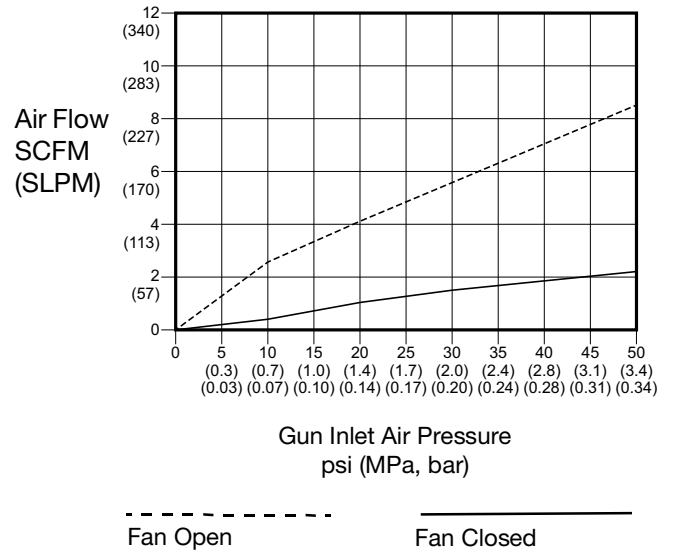

Graco Standard Warranty

Graco warrants all equipment referenced in this document which is manufactured by Graco and bearing its name to be free from defects in material and workmanship on the date of sale to the original purchaser for use. With the exception of any special, extended, or limited warranty published by Graco, Graco will, for a period of twelve months from the date of sale, repair or replace any part of the equipment determined by Graco to be defective. This warranty applies only when the equipment is installed, operated and maintained in accordance with Graco's written recommendations.

This warranty does not cover, and Graco shall not be liable for general wear and tear, or any malfunction, damage or wear caused by faulty installation, misapplication, abrasion, corrosion, inadequate or improper maintenance, negligence, accident, tampering, or substitution of non-Graco component parts. Nor shall Graco be liable for malfunction, damage or wear caused by the incompatibility of Graco equipment with structures, accessories, equipment or materials not supplied by Graco, or the improper design, manufacture, installation, operation or maintenance of structures, accessories, equipment or materials not supplied by Graco.

This warranty is conditioned upon the prepaid return of the equipment claimed to be defective to an authorized Graco distributor for verification of the claimed defect. If the claimed defect is verified, Graco will repair or replace free of charge any defective parts. The equipment will be returned to the original purchaser transportation prepaid. If inspection of the equipment does not disclose any defect in material or workmanship, repairs will be made at a reasonable charge, which charges may include the costs of parts, labor, and transportation.

THIS WARRANTY IS EXCLUSIVE, AND IS IN LIEU OF ANY OTHER WARRANTIES, EXPRESS OR IMPLIED, INCLUDING BUT NOT LIMITED TO WARRANTY OF MERCHANTABILITY OR WARRANTY OF FITNESS FOR A PARTICULAR PURPOSE.

Graco's sole obligation and buyer's sole remedy for any breach of warranty shall be as set forth above. The buyer agrees that no other remedy (including, but not limited to, incidental or consequential damages for lost profits, lost sales, injury to person or property, or any other incidental or consequential loss) shall be available. Any action for breach of warranty must be brought within two (2) years of the date of sale.

GRACO MAKES NO WARRANTY, AND DISCLAIMS ALL IMPLIED WARRANTIES OF MERCHANTABILITY AND FITNESS FOR A PARTICULAR PURPOSE, IN CONNECTION WITH ACCESSORIES, EQUIPMENT, MATERIALS OR COMPONENTS SOLD BUT NOT MANUFACTURED BY GRACO. These items sold, but not manufactured by Graco (such as electric motors, switches, hose, etc.), are subject to the warranty, if any, of their manufacturer. Graco will provide purchaser with reasonable assistance in making any claim for breach of these warranties.

In no event will Graco be liable for indirect, incidental, special or consequential damages resulting from Graco supplying equipment hereunder, or the furnishing, performance, or use of any products or other goods sold hereto, whether due to a breach of contract, breach of warranty, the negligence of Graco, or otherwise.

FOR GRACO CANADA CUSTOMERS

The Parties acknowledge that they have required that the present document, as well as all documents, notices and legal proceedings entered into, given or instituted pursuant hereto or relating directly or indirectly hereto, be drawn up in English. Les parties reconnaissent avoir convenu que la rédaction du présente document sera en Anglais, ainsi que tous documents, avis et procédures judiciaires exécutés, donnés ou intentés, à la suite de ou en rapport, directement ou indirectement, avec les procédures concernées.

Graco Information

For the latest information about Graco products, visit www.graco.com.

For patent information, see www.graco.com/patents.

TO PLACE AN ORDER, contact your Graco distributor or call to identify the nearest distributor.

Phone: 612-623-6921 **or Toll Free:** 1-800-328-0211, **Fax:** 612-378-3505

All written and visual data contained in this document reflects the latest product information available at the time of publication. Graco reserves the right to make changes at any time without notice.

Original instructions. This manual contains English. MM

Graco Headquarters: Minneapolis

International Offices: Belgium, China, Japan, Korea

GRACO INC. AND SUBSIDIARIES • P.O. BOX 1441 • MINNEAPOLIS MN 55440-1441 • USA
Copyright 2021, Graco Inc. All Graco manufacturing locations are registered to ISO 9001.

www.graco.com
Revision D, February 2024