

GL-1™ Injectors





308953ZAC
EN

For Single-Line Parallel Automatic Lubrication Systems.



Important Safety Instructions

Read all warnings and instructions in this manual and related automatic lubrication system instruction manuals. Save all instructions.

						
SKIN INJECTION HAZARD						
<p>Fluid from the injector, leaks, or ruptured components can inject fluid into your body and cause extremely serious injury, including the need for amputation. Fluid injected into the skin might look like just a cut, but it is a serious injury. Get immediate surgical treatment. Fluid splashed in the eyes or on the skin can also cause serious injury. The equipment may be pressurized already, or it could become pressurized by an automatic lube cycle initiated by Lubrication Controller (timer). Disconnect power to the timer, and disconnect the air supply to the pump module to ensure that the system is depressurized. See the pressure relief procedure in the pump manual included with your automatic lubrication system.</p>						

Model 114903 Shown

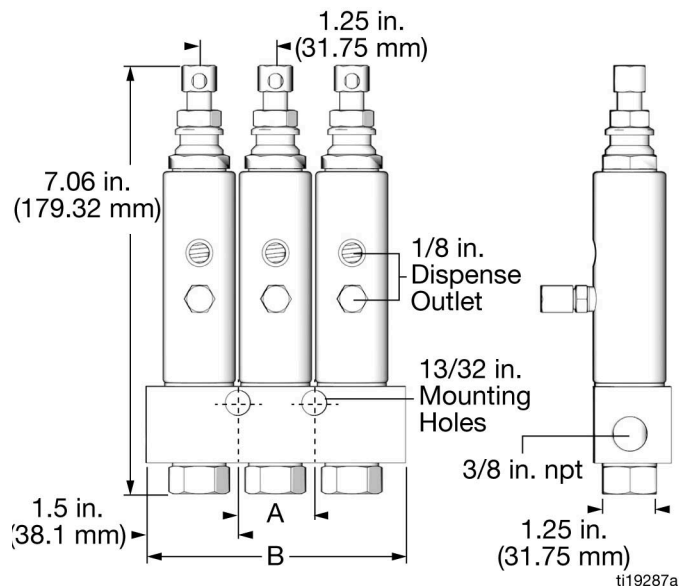

GL-1 Injector Models

Part No.	Description	Dimension A	Dimension B	Bare Manifold Part No.
114901	Injector, GL-1, one point		2.48 in. (63.0 mm)	114911
114902	Injector, GL-1, two point		3.00 in. (76.0 mm)	114912
114903	Injector, GL-1, three point	1.25 in. (31.7 mm)	4.23 in. (107.5 mm)	114913
114904	Injector, GL-1, four point	2.50 in. (63.4 mm)	5.47 in. (139.0 mm)	114914
114905	Injector, GL-1, five point	3.75 in. (95.1 mm)	6.71 in. (170.5 mm)	114915
117206	Injector, GL-1, six point	4.99 in. (126.8 mm)	7.90 in. (202.7 mm)	118206
114909	Injector, GL-1, replacement			
25N109	Injector, SST, replacement			

Installation Instructions

The reference letters used in the following instructions refer to the figure on page 3.

- Group injectors to minimize feed line length.
- Install injectors in locations that allow easy and safe servicing access.
- Install injectors in areas that minimize accidental injector damage by moving equipment.
- Injector outputs can be combined for a common bearing point with a large grease requirement but the output for a single injector cannot be split into multiple bearing points.
- Use steel tubing instead of pipe and hose for supply lines when possible. Pipe is often contaminated with scale and requires proper cleaning prior to use. Hose lines expand under pressure which leads to longer pump cycle time.



1. Relieve pressure. See **Pressure Relief Procedure**, in the pump instruction manual included with your automatic lubrication system.
2. Install injectors on a flat, hard surface using mounting brackets.
3. Connect fluid supply line to injectors.

NOTICE

To prevent rupturing supply lines due to over-pressurizing the components, only use supply lines and fittings that meet or exceed the pressure rating of the injectors.

4. Connect lube point feed lines.
5. Flush the system with low viscosity oil or mineral spirits to remove contamination introduced during installation.
6. Use a purge gun or run the pump until clean lubricant is dispensed at the end of each feed line to purge the system of flushing fluid or air.

7. Run the system at full output and verify that all injectors are cycling.
8. Adjust injector volume output. see **Volume Adjustment**, page 2.
9. Connect feed lines to lubrication points.

Volume Adjustment

*Maximum adjustment setting is when the adjusting screw (2) is just making contact with the indicator pin (8) with no inlet pressure. Turn the adjusting screw clockwise (in) to reduce output. To adjust, loosen the lock nut (3) and turn the adjusting screw (2) the number of turns indicated on the GL-1 Volume Adjustment Table to obtain the desired volume. Tighten the lock nut (3) when the desired volume setting is reached.

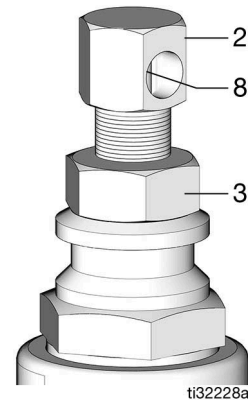

Description	Number of Turns	Volume	
		in. ³	cc
Maximum Adjustment*	0	0.080	1.31
360° Clockwise Turn	1	0.071	1.16
360° Clockwise Turn	2	0.062	1.02
360° Clockwise Turn	3	0.053	0.87
360° Clockwise Turn	4	0.044	0.72
360° Clockwise Turn	5	0.035	0.57
360° Clockwise Turn	6	0.026	0.43
360° Clockwise Turn	7	0.017	0.28
Minimum Adjustment	8	0.008	0.13

Injector Service Parts

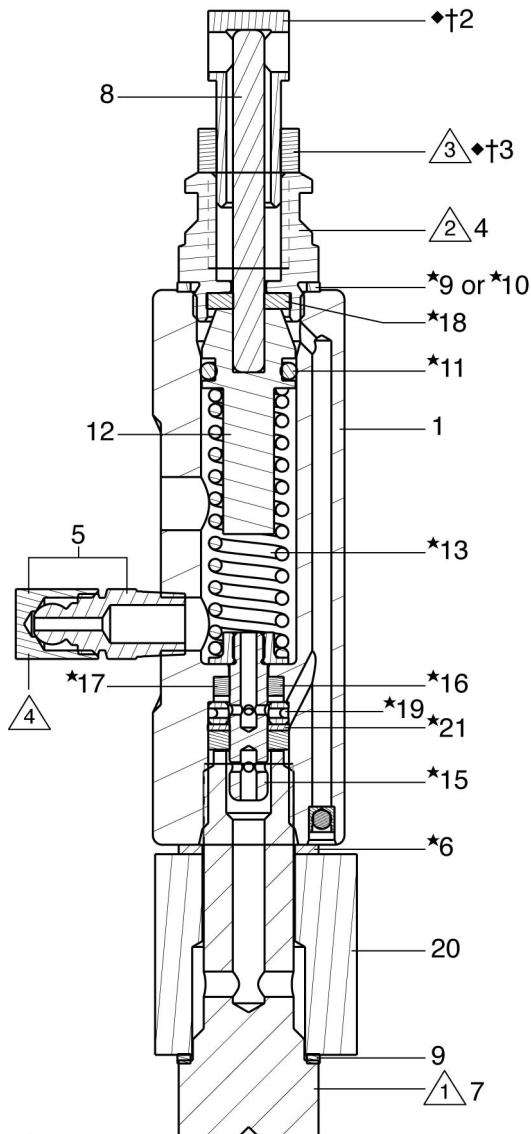

- ① Torque to 50-55 ft-lbs (68-74.6 N•m)
- ② Torque to 35-40 ft-lbs (47-54 N•m)
- ③ Torque to 5-10 ft-lbs (6.5-13.5 N•m)
- ④ Torque to 60-70 in-lbs (6.7-7.9 N•m) *Lubricated
ti25095b

NOTE: The injector has either 9 or 10, as determined by body style. Determine which part is needed from Repair Kit 241234 and discard the other.

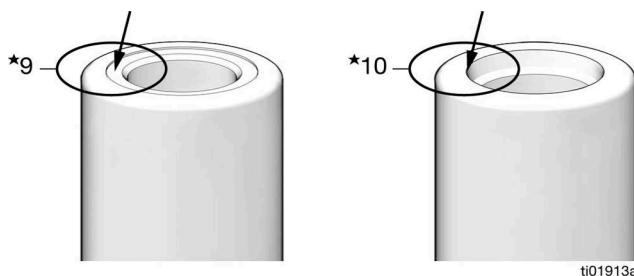

Ref	Part No.		Description	Qty
	Carbon Steel	SST		
1	-	-	Injector body	1
2	◆	†	Adjusting screw	1
3	◆	†	Lock nut	1
4			Packing housing	1
5	17Y511	17Y498	Zerk fitting and cap assembly	1
6	★	★	Copper gasket	1
7	-	-	Adapter bolt (used on all manifold models)	1
8	-	-	Indicator pin	1
9	★	★	Steel gasket	2
10	★	-	O-ring	1
11	★	★	Fluoroelastomer o-ring (PN 114997)	1
12			Displacement piston	1
13	★	★	Compression spring	1
15	★	★	Poppet Assembly	1
16	★	★	Fluoroelastomer packing	1
17	★	★	Fluoroelastomer packing	1
18	★	★	Fluoroelastomer packing	1
19	★	★	Inlet valve	1
20			Manifold, bare	1
21	★	★	Back up ring	1
	114911	25N101	• One bank	
	114912	25N102	• Two bank	
	114913	25N103	• Three bank	
	114914	25N104	• Four bank	
	114915	25N105	• Five bank	
	118206	25N106	• Six bank	
★ Included in Injector Repair Kit 241234 only				
◆ Included in Screw with Adjusting Nut Kit 17Y510				
† Included in Screw with Adjusting Nut Kit 17Y489				

Available Kits

Use Only Genuine Graco Repair Parts

- Graco Part No. 114909:** Replacement Injector only (does not include manifold).
- Graco Part No. 25N109:** Replacement SST Injector only (does not include manifold).
- Graco Part No. 17L754:** Clear Polycarbonate Injector Cover. See page 4 for installation instructions.
- Graco Part No. 133095:** Crossover Kit (for connecting the injector outlets to increase output)
- Graco Part No. 241234:** Injector Repair Kit (See parts in **Injector Service Parts.**)
- Graco Part No. 25D336:** Cap kit (see page 4)
- Spacer Kits - 10 Pack:** See Table and instructions, page 4.

Injector Cover Kit 17L754

Item	Description	Qty
21	Cap	1
22	O-ring	1

Installation Instructions

1. Apply a light coating of transparent lubricant to the inside of the cap (21).
2. Slide the o-ring (22) down over the indicator stem to the groove in the piston plug.
3. Slide the cap (21) over the indicator stem of the injector far enough to cover the groove in the piston plug.

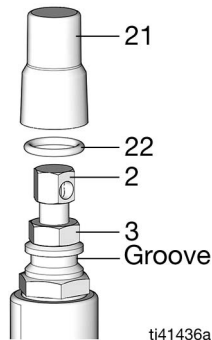

Cap Kit 25D336

Ref	Description	Qty
20	Plug	1
21	Washer, bonded 13.8 I.D.	1
22	Gasket, steel, 18.3 ID x 26.5 OD	1
23	Bolt, adapter	1

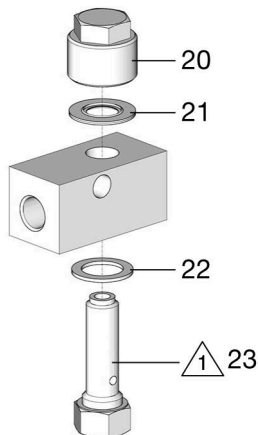

 Torque to 50-55 ft-lbs (67.8-74.6 N•m)
ti32152a

Spacer Kits

Spacer Kit Table

Part No.	color	Output Target		Output Target Ratio	
		cu. in.	cc	From minimum	From max
NA	NA	0.01	0.1	1.0	0.10
17K601	Red	0.03	0.5	2.0	0.50
17K602	Sliver	0.04	0.7	3.0	0.60
17K603	Gold	0.06	0.8	4.0	0.80
17K604	Green	0.07	1.2	5.0	1.00
17K417	NA	0.112	1.87	NA	NA



1. Relieve pressure. See **Pressure Relief Procedure**, in the pump instruction manual included with your automatic lubrication system.
2. Remove the adjusting screw (2) and jam nut (3) from the injector. Discard the jam nut.

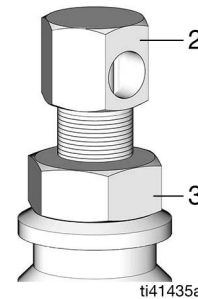

3. Insert color-coded spacer (sp) for desired output (see Spacer Kit Table). Reinstall the adjusting screw (2) in the injector. Hand tighten securely and torque to 60 in.-lbs (6.7 N•m) ± 10.

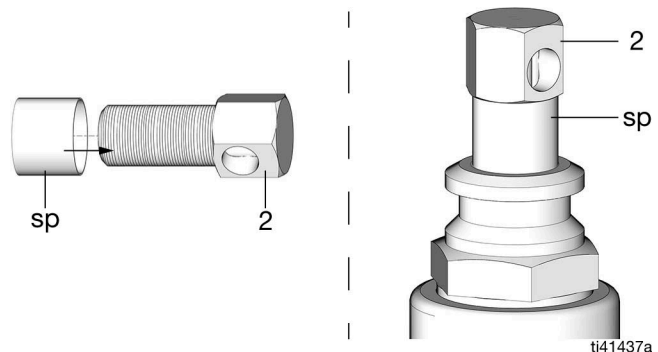

Technical Data

Maximum operating pressure	3500 psi (24 MPa, 241 bar)
Suggested operating pressure	2500 psi (17 MPa, 172 bar)
Reset pressure	600 psi (4.1 MPa, 41 bar)
Output volume per cycle	adjustable*: 0.008 to 0.08 in. ³
Wetted parts	carbon steel, stainless steel, UHMWPE, fluoroelastomer
Recommended fluids	N.L.G.I. #2 grease down to 32° F (0° C)

Graco Standard Warranty

Graco warrants all equipment referenced in this document which is manufactured by Graco and bearing its name to be free from defects in material and workmanship on the date of sale to the original purchaser for use. With the exception of any special, extended, or limited warranty published by Graco, Graco will, for a period of twelve months from the date of sale, repair or replace any part of the equipment determined by Graco to be defective. This warranty applies only when the equipment is installed, operated and maintained in accordance with Graco's written recommendations.

This warranty does not cover, and Graco shall not be liable for general wear and tear, or any malfunction, damage or wear caused by faulty installation, misapplication, abrasion, corrosion, inadequate or improper maintenance, negligence, accident, tampering, or substitution of non-Graco component parts. Nor shall Graco be liable for malfunction, damage or wear caused by the incompatibility of Graco equipment with structures, accessories, equipment or materials not supplied by Graco, or the improper design, manufacture, installation, operation or maintenance of structures, accessories, equipment or materials not supplied by Graco.

This warranty is conditioned upon the prepaid return of the equipment claimed to be defective to an authorized Graco distributor for verification of the claimed defect. If the claimed defect is verified, Graco will repair or replace free of charge any defective parts. The equipment will be returned to the original purchaser transportation prepaid. If inspection of the equipment does not disclose any defect in material or workmanship, repairs will be made at a reasonable charge, which charges may include the costs of parts, labor, and transportation.

THIS WARRANTY IS EXCLUSIVE, AND IS IN LIEU OF ANY OTHER WARRANTIES, EXPRESS OR IMPLIED, INCLUDING BUT NOT LIMITED TO WARRANTY OF MERCHANTABILITY OR WARRANTY OF FITNESS FOR A PARTICULAR PURPOSE.

Graco's sole obligation and buyer's sole remedy for any breach of warranty shall be as set forth above. The buyer agrees that no other remedy (including, but not limited to, incidental or consequential damages for lost profits, lost sales, injury to person or property, or any other incidental or consequential loss) shall be available. Any action for breach of warranty must be brought within two (2) years of the date of sale.

GRACO MAKES NO WARRANTY, AND DISCLAIMS ALL IMPLIED WARRANTIES OF MERCHANTABILITY AND FITNESS FOR A PARTICULAR PURPOSE, IN CONNECTION WITH ACCESSORIES, EQUIPMENT, MATERIALS OR COMPONENTS SOLD BUT NOT MANUFACTURED BY GRACO. These items sold, but not manufactured by Graco (such as electric motors, switches, hose, etc.), are subject to the warranty, if any, of their manufacturer. Graco will provide purchaser with reasonable assistance in making any claim for breach of these warranties.

In no event will Graco be liable for indirect, incidental, special or consequential damages resulting from Graco supplying equipment hereunder, or the furnishing, performance, or use of any products or other goods sold hereto, whether due to a breach of contract, breach of warranty, the negligence of Graco, or otherwise.

FOR GRACO CANADA CUSTOMERS

The Parties acknowledge that they have required that the present document, as well as all documents, notices and legal proceedings entered into, given or instituted pursuant hereto or relating directly or indirectly hereto, be drawn up in English. Les parties reconnaissent avoir convenu que la rédaction du présente document sera en Anglais, ainsi que tous documents, avis et procédures judiciaires exécutés, donnés ou intentés, à la suite de ou en rapport, directement ou indirectement, avec les procédures concernées.

Graco Information

For the latest information about Graco products, visit www.graco.com.

TO PLACE AN ORDER, contact your Graco distributor or call to identify the nearest distributor.

Phone: 612-623-6928 or **Toll Free:** 1-800-533-9655, **Fax:** 612-378-3590

All written and visual data contained in this document reflects the latest product information available at the time of publication. Graco reserves the right to make changes at any time without notice.

For patent information, see www.graco.com/patents.

Original instructions. This manual contains English. MM 308953

Graco Headquarters: Minneapolis
International Offices: Belgium, China, Japan, Korea

GRACO INC. AND SUBSIDIARIES • P.O. BOX 1441 • MINNEAPOLIS MN 55440-1441 • USA

Copyright 1999, Graco Inc. All Graco manufacturing locations are registered to ISO 9001.

www.graco.com

Revision ZAC, April 2024